

Underhaug

*Two row
potato harvester
2700*

tkS

MEKANISKE

www.tksmek.com



2700 Underhaug

In-line harvesters with full width cleaning systems

The trend in modern potato growing continues towards increasingly variable row widths and bed systems, with a requirement for greater harvesting capacity. Therefore the need for today's harvesters to quickly and efficiently separate clean and undamaged potato samples from a variety of soil types grows ever more important.

Impressive capacity

Together with infinitely variable, electronically controlled hydraulic agitation

of the main and secondary webs, the consistently wide webs along the entire length of the harvester provide a massive 7.2 m² separation area and efficiency that's second to none. The 3 stage high capacity 1100 mm wide hydraulically powered unloading elevator with adjustable speed control ensures gentle handling of a variety of crop sizes in different soil and weather conditions.

Good visibility

The low, in-line design of

the 2700 affords the driver exceptional visibility along the entire length of the harvester. This allows close monitoring of the separation process and prompt adjustment of the machine to achieve the best possible results. The design also provides the added bonus of good manoeuvrability on headlands and during transport.



Unique floating lifting unit follows the ground contours.

Wide working width

Underhaug's new 2700 harvester features a 1650mm wide main web, within a 1680 mm wide lifting unit, making it ideally suited to row widths up to 100cm and bed systems to

200cm. The full width design is common throughout the whole separation area of the machine, including the picking table, so providing high output without congestion. A new

3 roller positive main web drive facilitates easy changing of webs to suit different crop and field conditions.



Flight conveyor on main web (option). Extra cleaning. Stops the crop from rolling back.

User friendly

Designed from the outset to enhance both harvester and operator performance, the 2700 enjoys a variety of 'state-of-the-art' features that offer a host of operational advantages. Electronic in-cab control of the hydraulic steering, wheel drive, depth control, frame levelling, axial roller operating angle and haulm elevator working angle enhances output and encourages adjustment of the machine" various functions to maximise the efficiency and lifting rate of the cleanest possible, damagefree crop samples. Also integrated

in the control system is the automatic raising of the unloading elevator when the frame is lowered from the picking off table. This minimises the opportunities for damage occurring to the elevator from trailers working alongside the harvester.



Control panel for picking table.



The 3 roller positive main web drive system facilitates easy changing of webs to suit different crop and field conditions.



'Free flow' picking table

The 1650 mm wide, high capacity adjustable speed picking off table comfortably accommodates up to four people, and is easily adjustable up or down to suit the size of the operators. Picking table speed and frame levelling can also be controlled from the picking off table, enabling fine adjustment of the harvester's performance.

Flotation wheels with hydraulic steering reduce soil compaction and ease manoeuvrability in difficult conditions. Other wheel options are available.

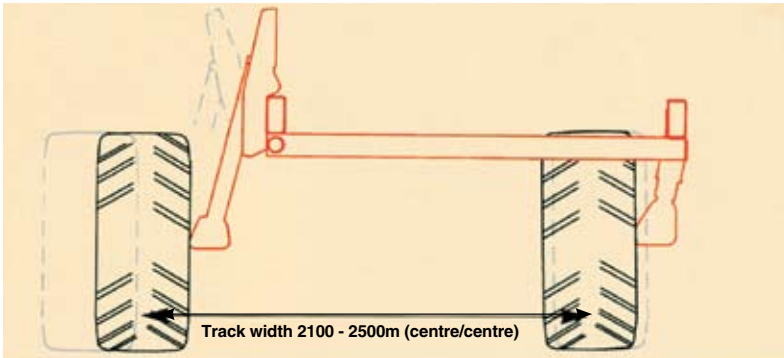

Finger tip controlled wheel drive

The optional hydraulically powered wheel drive is easily operated from the tractor seat simply by pushing a key on the control panel. The load sensing axial piston pump provides 3300Nm of torque to improve the mobility in wet conditions. When the harvester's speed increases beyond approx. 8km/h the drive is automatically disengaged. The wheel drive can also be reversed for maximum flexibility of use.

Ingenious axle design for flexibility and efficiency

Intensive research has produced a unique new centrally-mounted axle that offers operators the advantage of being able to easily adapt the 2700's wheel track, working angle, and steering to a variety of field and operating conditions. The hydraulic levelling and selaligning wheel steering functions have been integrated into the system from the initial design stages,



so that it is even possible to fit additional wheel equipment to the harvester whilst retaining the steering facility.

Teleweb (option).

Can be retracted or extended to reveal or cover more or less of the axial rollers.



1650mm wide main web and second web for improved separation.

The operator's platform can easily be folded up to reduce transport width.



Highly effective integrated axial cleaning rollers

The 18 axial rollers fitted to the 2700 represent a unique primary cleaning system for removing soil, clods and small stones, and they cover the full 1650 mm web width of the harvester. The rollers are positioned in front of the picking table (if fitted) or unloading elevator, and driven by the harvester's own

independent hydraulic motor. Their working angle can be adjusted from the tractor seat, to maximise the efficiency of the roller unit according to crop and field conditions. Roller rotation speed is also adjustable, with plain rollers available in a variety of diameters. The rollers expel large stones automatically,

via the auto-reverse system, so minimising the potential for damage to the rollers and to the tubers during their passage through the harvester. Furthermore, each roller in the unit can be removed and reversed to maximise its life expectancy, thereby reducing maintenance costs.

As another alternative the 2700 can be supplied with a star roller table instead of the axial rollers.



**Two row un-manned potato harvester
2707**

The versatile harvester for all conditions.

Primary cleaning system:

Full width (1650 mm) third sieving web.

Two haulm rollers.

Secondary cleaning system:

Full width (1650 mm) haulm elevator with stripping roller and remote controlled working angle.

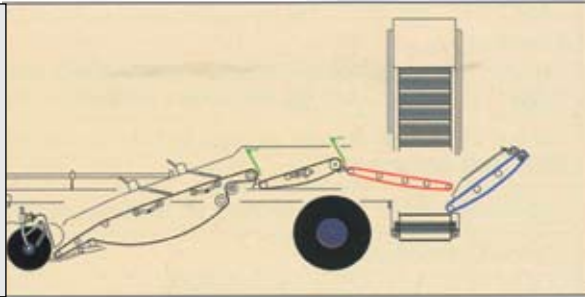

**Two row, un-manned potato harvester
2721**

The versatile two-row harvester for all conditions

Primary cleaning system:

Full width (1650 mm) axial roller unit (18 rollers)

Two haulm rollers.

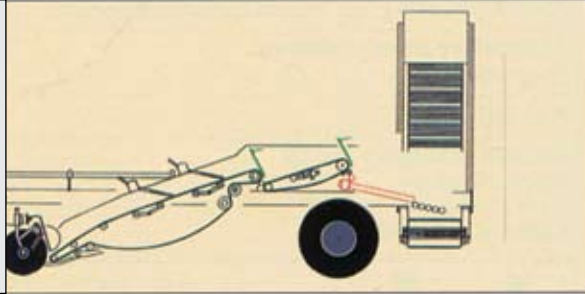

**Two row, manned potato harvester
2722**

The versatile two-row harvester for all conditions.

Primary cleaning system:

Full width (1650 mm) axial roller unit (18 rollers)

Two haulm rollers.

Secondary cleaning system:

Picking off table.

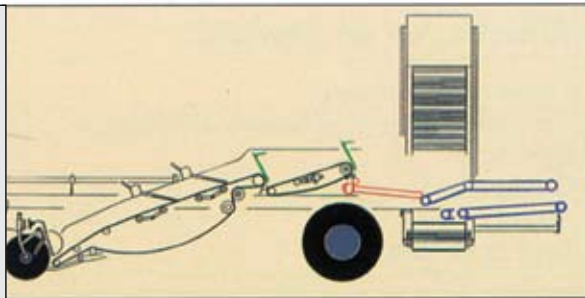

Underhaug 2700

- for professional growers

Specification ■ = standard ○ = option	2707	2721	2722
Hydraulics: Oil supply from tractor to solenoid operated valve bank for control of cylinder functions and elevator motor, integrated pumps with frame tank for drive of picking table and axial roller unit	■	■	■
Lifting unit: Floating lifting unit, three piece shares, pivoting 675mm roller discs with parallel stays, diabolos with mechanic depth control, 385 mm haulm pull in rollers at each side, lifting unit width to suit row widths 75-100 cm	■	■	■
Automatic, hydraulic controlled depth control offering reduced pressure on diabolos	○	○	○
Centre positionned haulm pull in roller, for row width 75-80 cm og 85-90 cm	○	○	○
Full width shares covering various row/bed widths, centre section depth can be set deeper/shallower than that of main sections	○	○	○
Half diabolos	○	○	○
Depth wheels	○	○	○
Carrot lifting kit	○	○	○
Drawbar: Adjustable height, hydraulic lane adjustment	■	■	■
First (main) sieving web: Web width 1650 mm, working length 3225 mm, infinite adjustable web agitation, three roller friction drive, double link joiners	■	■	■
Alternative main frame web gaps: 17 - 25 - 29 (std) - 34 - 39 mm	○	○	○
Second sieving web: Web width 1650 mm, working length 1140 mm, infinite adjustable web agitation, friction drive	■	■	■
Alternative second web gaps: 17 - 25 - 25 rubber coated - 29 (std) - 34 - 39 mm	○	○	○
Haulm removal: Spring loaded haulm rollers with easy positioning	■(2)	■(2)	■(2)
Haulm elevator with stripping roller and adjustable speed and adjustable working angle	■		
Primary cleaning system: Integrated 18 rollers axial cleaning unit (Ø 82mm smooth rollers, Ø82 mm auger rollers, both types rubber coated), infinite speed adjustment, hydraulic adjustment of working angle and angle indicator, all rollers cab be turned for extended life time		■	■
Automatic axial roller angle adjustment		○	○
Alternative axial rollers: Ø 75 or Ø 92 mm rubber coated smooth rollers		○	○
Third web replaces axial roller unit (for conditions not suitable for axial rollers)		○	○
Third sieving web	■		
Flight conveyor for main web	○	○	○
Teleweb for axial rollers	○	○	○

Choose your own features to suit your particular conditions

Specifications ■ = standard ○ = option	2707	2721	2722
Secondary cleaning system: 1650 mm wide picking table with infinite soeed adjustment, adjustable working height, suitable for 4 operators, alarm, sieving web agitation control, main frame levelling control with automatic raising of elevator when frame is lowered on right-hand side.			■
Haulm elevator with stripping roller and adjustable speed and adjustable working angle.	■		
Automatic haulm elevator working angle adjustment	○		
Wheel axle: Hydraulic frame levelling.	■	■	■
Automatic levelling.	○	○	○
Hydraulic wheel steering with automatic centre positioning and steering indicator included. Adjustable centre position.	■	■	■
Wheels 500/60-22,5" track type	■	■	■
Wheels 400/60-26,5" track type	○	○	○
Wheels 500/60-26,5" track type	○	○	○
Wheels 600/55-26,5" track type	○	○	○
Wheels 13.6/12-28" track type rh side only	○	○	○
Wheels 16.9/14-30" track type rh side only	○	○	○
Adjustable track width 2100-2500 mm c/c	■	■	■
Wheel axle extended to cope with bed systems	○	○	○
Wheel axle with hydraulic drive	○	○	○
Wheel brakes	○	○	○
Unloading elevator: Width 1100 mm (gross)/1000 mm (net), discharge height max. 3,50 m, fully hydraulic operated, adjustable speed	■	■	■
Spreading device for optimal distribution from axial roller or picking table in elevator		■	■
Automatic raising of elevator when the picking table's levelling control is lowering the frame on right-hand side			■
Canvas cover for elevator belt (stops loss of small tubers through belt)	○	○	○
Flexible chute for elevator end	○	○	○
Remote speed control	○	○	○
Alternative harvesting systems: Windrowing kits	○	○	○
Non-stop harvesting kit	○	○	○
Miscellaneous: Road lights	○	○	○
Canopy for picking table			○

Dimensions and weight:	2707	2721	2722
Length incl. drawbar	9.60 m	8.95 m	10.35 m
Transport height (w/500/60-22.5")	2.62 m	2.62 m	2.62 m
Width	2.91 m	2.91 m	2.91 m
Net weight	5400 kg	5300 kg	5650 kg
Axle load	4650 kg	4500 kg	4950 kg
Load on drawbar	750 kg	800 kg	700 kg

Underhaug Potato Planters. 2, 4 , 6 and 8 – row models



3780



3760



3745



3744



3740



3720



Torlandsveien 3, N-4365 Naerbo, Norway
Tlf. +47 51 43 63 00, Faxes +47 51 43 48 62
www.tksmek.com e-post: post@tksmek.no