

Underhaug

Operator's manual Superfaun single row potato harvester 1701-1725

UH121509

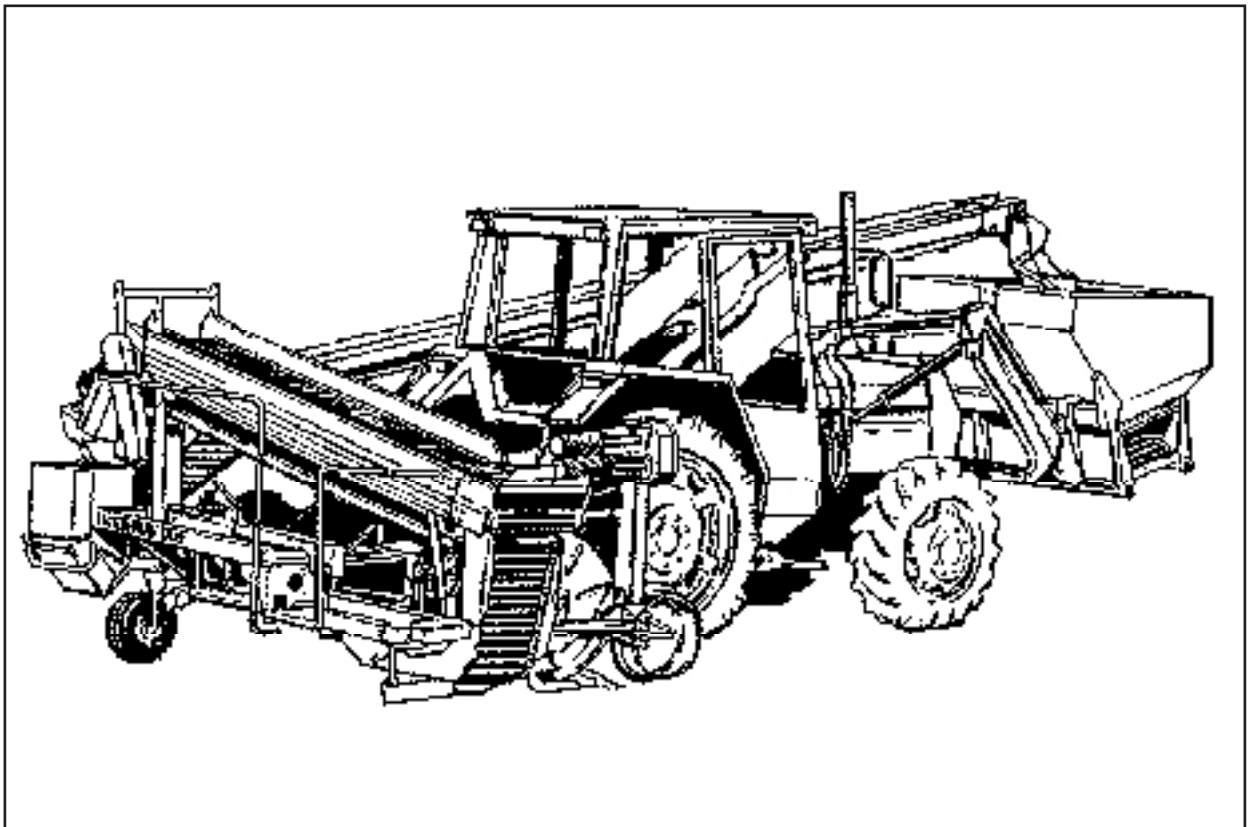

CE certificate of conformity

We,

**TKS Mekaniske AS,
Torlandsvegen 3
N-4365 Nærbø
Norway**

declare under our sole responsibility that the product:

Superfaun UN1700

to which this declaration relates corresponds to the relevant basic safety and health requirements of the Directives 89/392/EEC, 91/368/EEC, 93/44/EEC and 93/68/EEC.

Nærbø, 2. januar 2004



Henning Thunheim
Managing Director

Enter here the serial number of
your machine:

TKS, manufacturers of farm machinery reserve the right to change designs and/or specifications without notice. This does not include and obligation to make changes to machines previously supplied.

Guarantee

TKS products are guaranteed for a period of one year from the date of delivery, against defects in material and workmanship.

Component's not manufactured by TKS, i.e. electrics and hydraulics, p.t.o. shafts and tyres are guaranteed according to the original manufacturer's recommendation.

The components listed below have limited guarantee due to their function:

Tyres

Shares

Webs

Web rollers

Axial rollers

Fuses

Oil filter

Hydraulic seals for pumps, motors, valves and cylinders.

Weakening due to wear and tear is considered to be normal for these parts. The product guarantee for these components is limited to manufacturing defects, breakage, poor workmanship, transport damage etc on new machines.

If a failure is expected to be covered under the guarantee, the owner or its representative should inform the dealer when parts and/or repair work is required. Any guaranty claim should be applied for within the period of guarantee.

The dealer should fill in one guarantee claim form for each matter and forward it to the TKS sales company or importer before the 10th of the following month after the claim was raised.

The damaged parts should be marked with the number of the corresponding warranty claim and should be stored for 6 months by the dealer, available for inspection by the TKS sales company or importer if required.

Due to the operation of the TKS products being out of the manufacturer's control, the guarantee covers the product quality only. Performance or any consequential losses are not covered.

The guarantee may be invalid if:

- a) spurious spare parts are used or the product is repaired or modified without the TKS authorization.
- b) operators and service instructions given by the manufacturer are not complied with.
- c) The machine is used for other purposes than those designed for.

The guarantee does not cover damage caused by normal wear:

Public safety regulations require from the manufacturer of this machine that all safety aspects regarding the use of the machine is thoroughly evaluated. As a result of these obligations TKS and its importer or sales company are not responsible for the function of components not shown in the spare parts catalogue covering this product.

TKS reserve the right to change the product with no obligation to previously supplied machines.

CONTENTS

CE certificate of conformity.....	3	4. MACHINE OPERATION.....	31
Guarantee.....	4	4.1 Machine RPM.....	31
Introduction.....	6	4.2 Depth adjustment.....	31
Machine identification.....	7	4.3 Side positioning of the pick-up unit.....	31
Dimension.....	8	4.4 Digging wheel arms.....	31
Technical data.....	9	4.5 Soil separation.....	31
Model description.....	11	4.6 Haulm separation.....	31
Safety.....	13	4.7 Picking table speed.....	33
General safety precautions.....	13	4.8 Height of operator platform.....	33
Supplementary safety instructions for Underhaug Superfaun UN1700 single-row potato harvester	17	4.9 Variation of picking direction.....	33
Lifting of machine by crane.....	17	4.10 Changing of picking grade, sorting of small potatoes.....	33
Hazard with the use of chemicals.....	17	4.11 Emptying of stone box.....	33
New machine - caution!.....	19	4.12 Bearer wheel position.....	33
1. READYING OF NEW MACHINE.....	21	4.13 Road transport.....	33
1.1 Packing.....	21	5. MAINTENANCE.....	35
1.2 Mounting of wheels.....	21	5.1 Tyre pressure.....	35
1.3 Preparation of the lifting unit.....	21	5.2 Web tension.....	35
1.4 Installation of work platform.....	21	5.3 Chain/V-belt tension.....	35
1.5 Installation of protection shields above haulm roller.....	23	5.4 Safety switches.....	35
1.6 Readyng of conveyor.....	23	5.5 Adjustment of guide disc.....	35
1.7 Readyng of pick-up unit.....	26	5.6 Cleaning.....	37
1.8 Position of the turret.....	26	5.7 Lubrication.....	37
1.9 Readyng of accessories.....	27	5.8 Maintenance of drive shafts.....	37
2. TRACTOR REQUIREMENTS.....	27		
3. LINKAGE TO TRACTOR.....	29		
3.1 Basic machine.....	29		
3.2 Trailed conveyor.....	29		
3.3 Front-mounted pick-up unit.....	29		
3.4 Side conveyor.....	29		

Introduction

We congratulate on the purchase of your new TKS product. You have chosen a product which will give you satisfaction through a network of efficient dealers where gunction, finish, after sales service and spare parts are always at hand.

All TKS products are designed and tested in close co-operation with farmers and contractors to ensure optimal function and reliability.

Please read this manual before using your new machine.

We wish you all the best with your TKS product.

Good luck!

Yours faithfully

TKS Mekaniske AS



**TKS Mekaniske AS,
Torlandsveien 3
N-4365 Nærbø
Norway**

e-post : post@tksmek.no

Phone +47 51 43 63 00

Fax +47 51 43 48 62

Machine identification

The machine's serial number and the manufacturer's address is found on the number plate of the machine. See illustration below.

The serial number and year of delivery for this machine is given below. This number is important with regard to service and the correct supply of spare parts.

The machine is marked CE. This marking with appurtenant EU statement of agreement means that the machine complies with substantial health and security demands, and that it is accordance with the directives 89/392/ECC as amended by directive 91/368/ECC and 93/44/EEC.

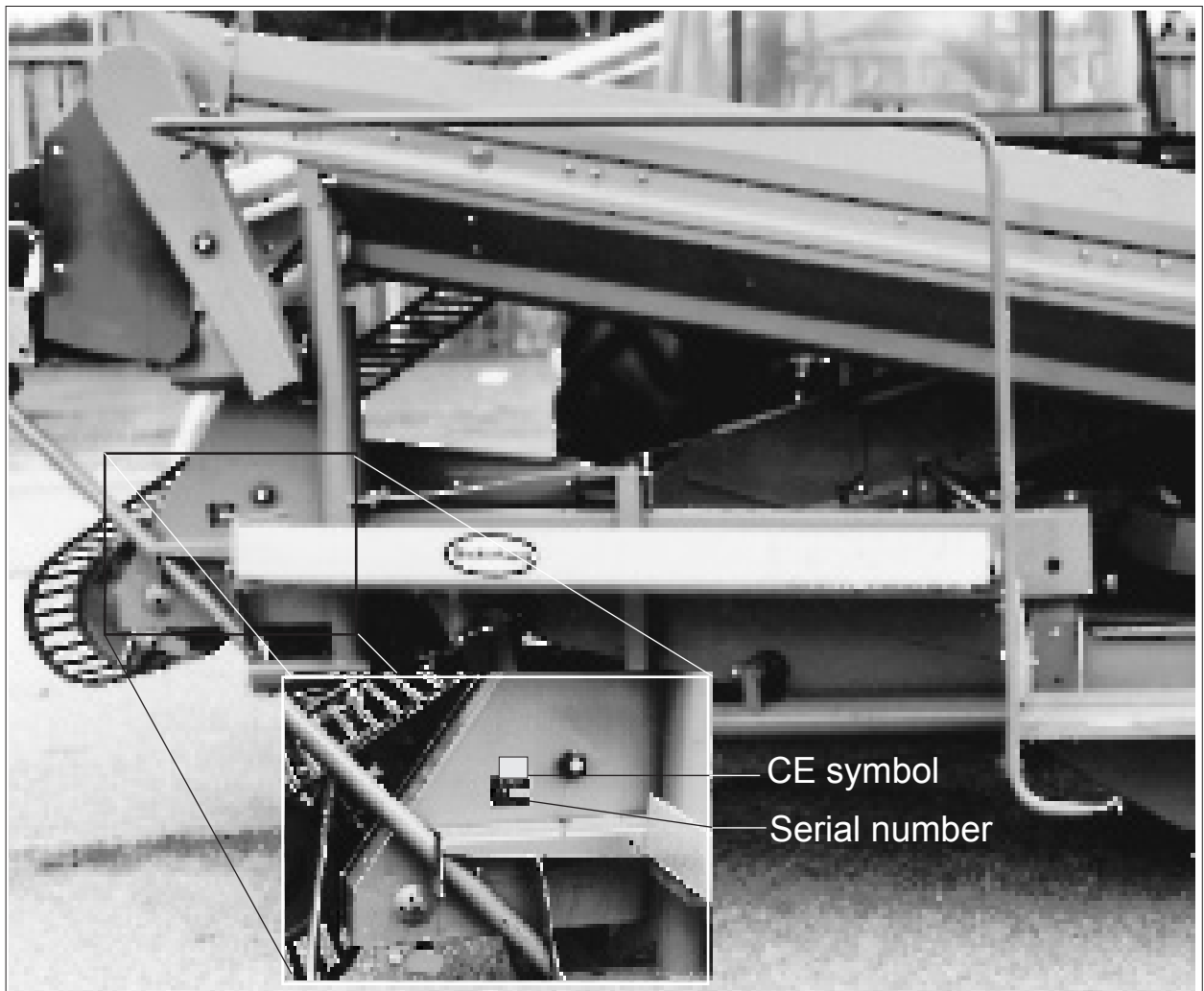

Serial number : _____

Year of delivery : _____

Dimension

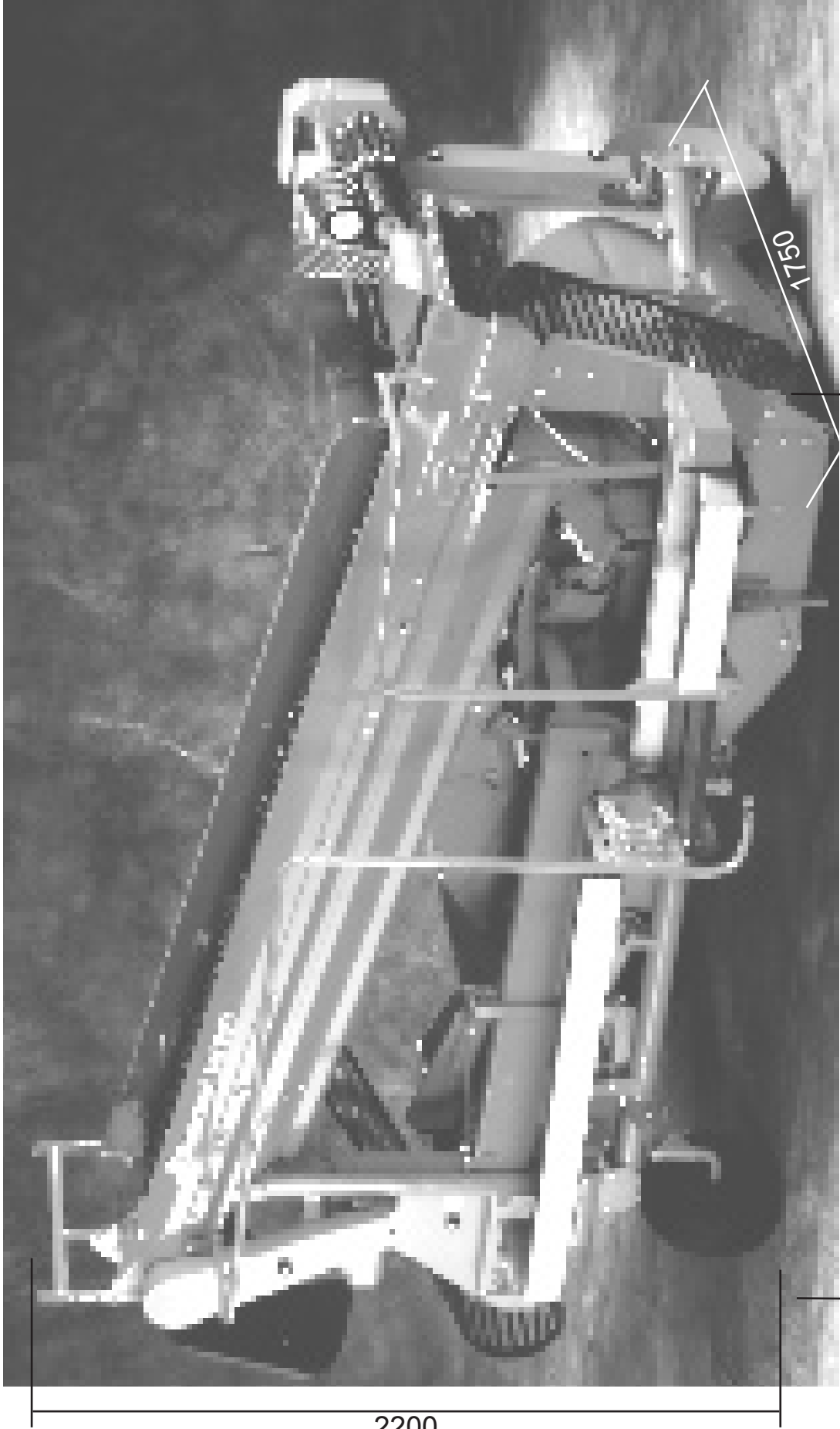

All measures are in mm (1" = 25.4mm)

Technical data

Model	UN1701	UN1720	UN1723	UN1724	UN1725
Lifting method	elevator	bagging platform on front-end loader	large box on front-end loader	tank on front-end loader	tank with moving floor
Number of rows	1	1	1	1	1
Linkage to tractor	Cat. 2	Cat. 2	Cat. 2	Cat. 2	Cat. 2
Row distance					
small share (extra)	65-75 cm	65-75 cm	65-75 cm	65-75 cm	65-75 cm
large share (standard)	75-90 cm	75-90 cm	75-90 cm	75-90 cm	75-90 cm
Loading capacity	-	750kg	1,500kg	1,000kg	1,100kg
Normal capacity	0.1-0.2 ha/h	0.1-0.2 ha/h	0.1-0.2 ha/h	0.1-0.2 ha/h	0.1-0.2 ha/h
Separation area					
first web	1.3m ²	1.3m ²	1.3m ²	1.3m ²	1.3m ²
second web	1.0m ²	1.0m ²	1.0m ²	1.0m ²	1.0m ²
Web, rod spacing					
all webs (extra)	21mm	21mm	21mm	21mm	21mm
all webs (standard)	25mm	25mm	25mm	25mm	25mm
first and second web (extra)	30mm	30mm	30mm	30mm	30mm
Web width					
first web	500mm	500mm	500mm	500mm	500mm
second web	350mm	350mm	350mm	350mm	350mm
sorting web	650mm	650mm	650mm	650mm	650mm
Machine width					
in working position	6.00m*	4.00m	4.00m	4.00m	4.00m
in transport position	2.30m	2.30m	2.30m	2.30m	2.30m
Lengths of basic machine (three-point mounting, basic unit) measured from the end of the drawbars.					
in working position	1.75m	1.75m	1.75m	1.75m	1.75m
in transport position	4.60m	4.60m	4.60m	4.60m	4.60m
Wheel dimension	LP190-8"	LP190-8"	LP190-8"	LP190-8"	LP190-8"
Weight, empty machine	1,090kg	1,240kg	1,190kg	1,300kg	1,420kg
of which basic machine	1,020kg	1,020kg	1,020kg	1,020kg	1,020kg
Smallest tractor size					
hydraulic lifting capacity	1,600kg	1,500kg	1,500kg	1,500kg	
motor output	50HP (37kW)	50HP (37kW)	50HP** (37kW)	50HP** (37kW)	50HP** (37kW)

*) lower edge fall damper 1.8m above the ground

***) recommend 4WD and min. 65HP (48kW) if loading capacity is to be fully utilized

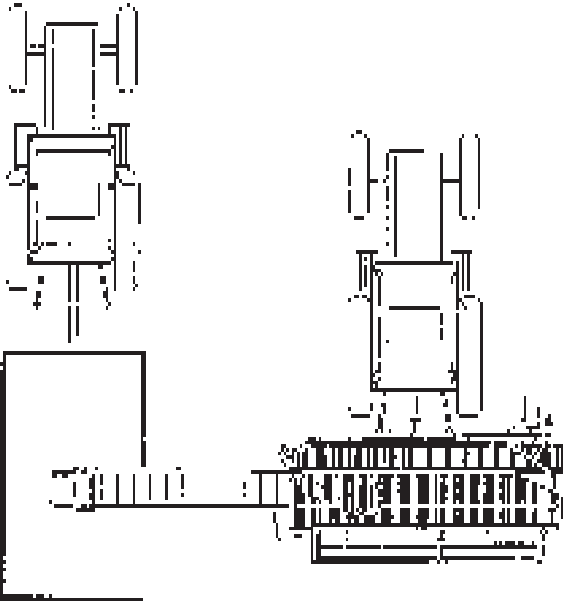

UN1701

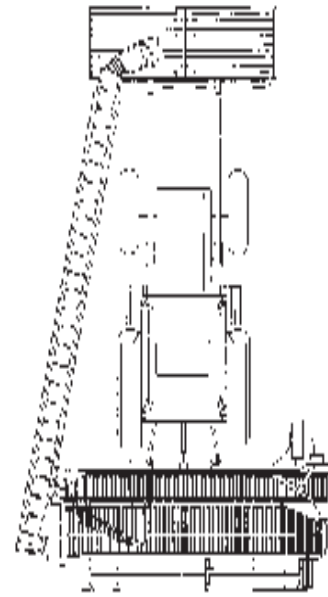

UN1723

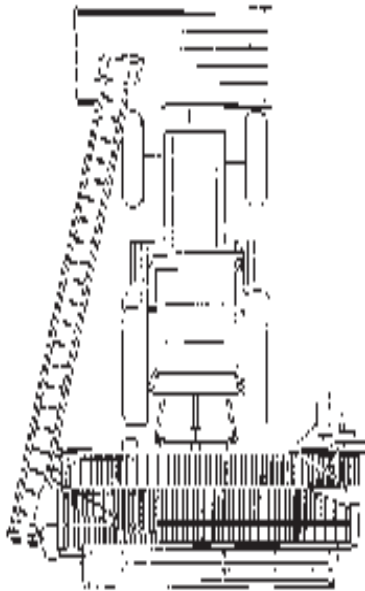

UN1720

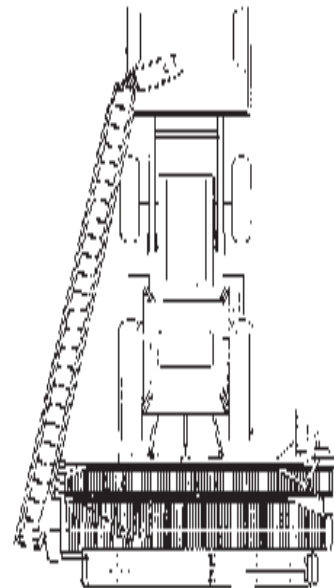

UN1724

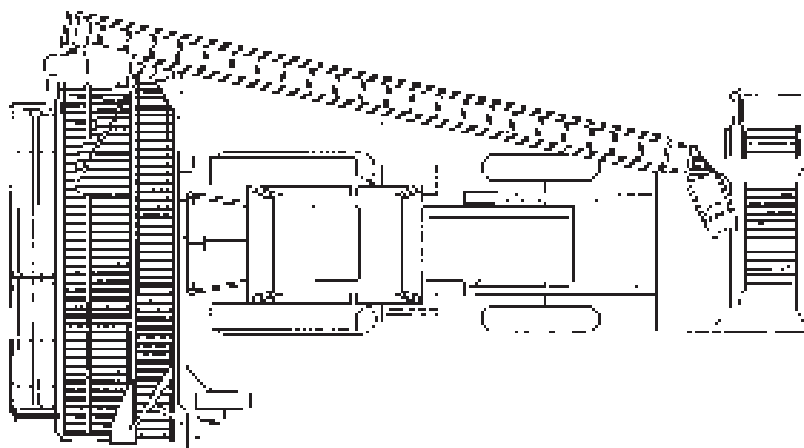

UN1725

Model description

Superfaun UN1700 single-row potato harvesters from Dunor Potato Group B.V. feature three-point linkage and side-mounted lifting unit. It has a lifting unit with a full share and a rotating digging wheel, which together feed the products onto the crossing first web. Depth is controlled by means of a roller disc with brim. The machine has two double haulm rollers. The work platform has room for 4 persons. The machine is available in the following variants (all based on the same three-point mounted basic machine):

- with trailed elevator
- with side conveyor and front-end-loader-mounted bagging platform
- with side conveyor and front-end-loader-mounted double box fork
- with side conveyor and front-end-loader-mounted tank with discharge hatch
- with side conveyor and front-end-loader-mounted tank with moving floor

The machine has a lifting share for a row distance of 75-90 cm; however, it can also be supplied with a smaller share for row distances up to 75 cm. The standard web rod spacing is 25mm, but other spacings are available to order (see technical data).

The machine includes equipment for conversion to trailed transport, i.e. behind the tractor.

The machine is available with the following additional equipment.

- haulm cutter
- stone tank
- sorter for small potatoes (not for machines with elevator)
- superstructure

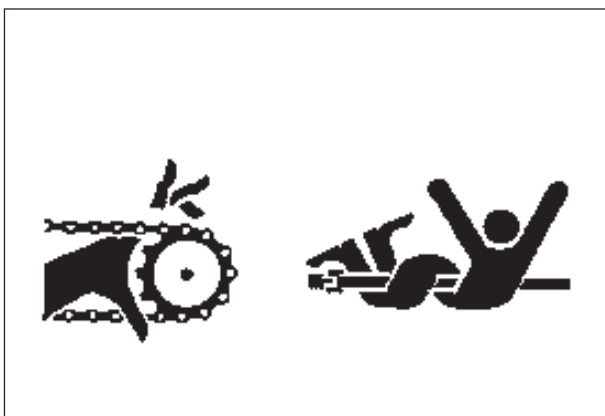
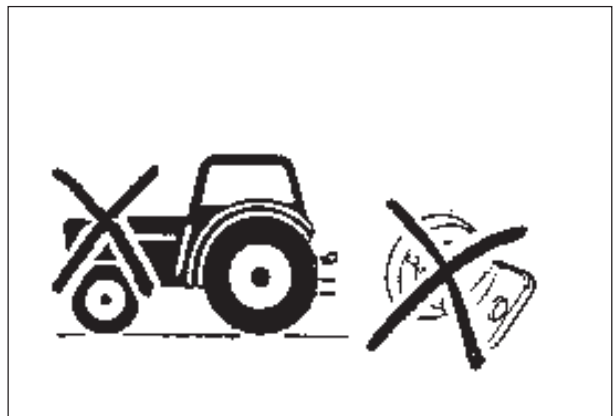
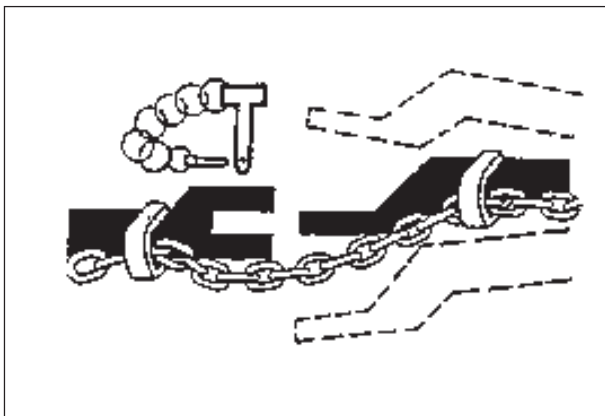
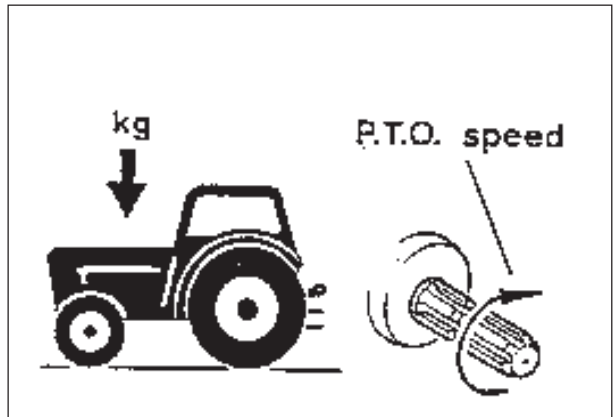
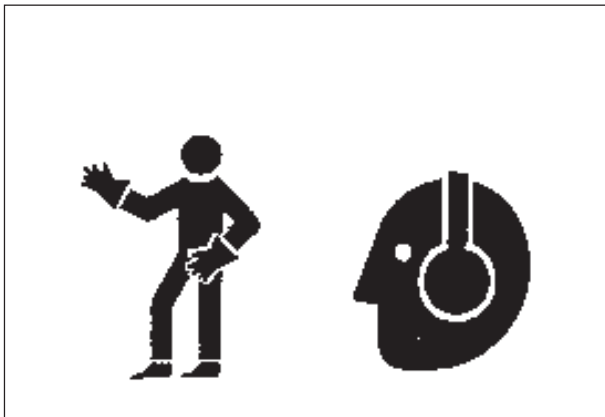
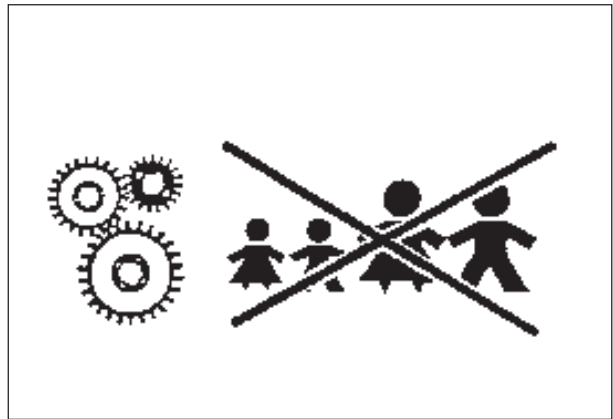
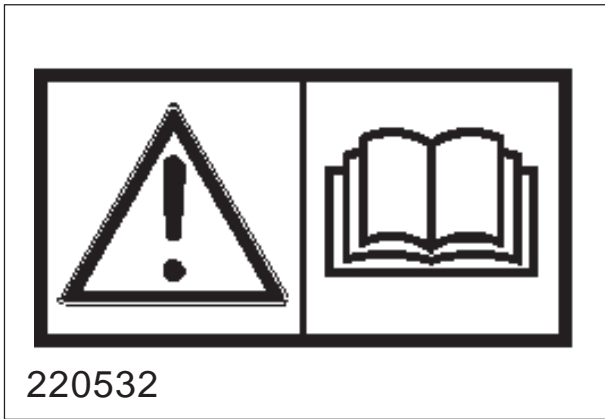

Safety

Before operating, adjusting or servicing the machine it is important that the safety instructions in this manual are carefully read and understood by those directly concerned (Fig. 1).

Whilst all care and attention has been taken in the design and production of this machine, as with all machinery there remains a certain amount of risk to personnel whilst the machine is in use. It is strongly recommended that users and operators take all possible precautions to ensure both their own safety and that

of the others that may be in the vicinity. Read and observe the safety instructions in this manual. Safety is your responsibility!



Pay particular attention to this symbol. It means that there could be a serious hazard. It emphasises precautions which have to be complied with in order to prevent accidents.

This symbol can be found throughout this manual and on the warning signs of the machine. They are for your safety and should be observed at all time.

General safety precautions

Be careful when other people or animals are close by!

Never start the machine when people or animals are close by tractor or machine.

Never stand between the tractor wheels and the machine. (Fig. 2)

Bear in mind regulations regarding the lower age of operators of this kind of machines.

Use of the machine

The machine should be used only for the purpose it has been designed for.

Use personal protection devices

Do not wear loose clothing which might catch in any of the moving parts. In dusty conditions an approved mask must be used. (Fig. 3)

Take care of excessive noise level. Some tractor/implement combinations, depending on conditions, may cause noise level beyond 85dB at the operator's ears, even in a 'Q' cab. In these conditions ear defenders must be worn. Keep cab windows and doors closed to reduce noise level.

The machine must be connected to a correctly sized tractor

The weight of the tractor must correspond to the maximum weight of the machine when operated. Follow domestic law and regulations. (Fig. 4)

Make sure that the tractor has the correct P.T.O. gear engaged. A machine designed for an input speed of 540 r.p.m. should never be connected to a tractor with 1000 r.p.m. output speed engaged. The normal P.T.O. speed is given on a label close to the P.T.O. input shaft.

Connecting machine to tractor

must always be carried out as described in this manual. If connection should be carried out with drawbar, one of the parts (tractor's or machine's drawbar) must have a clevis. The drawbar pin must be secured with a lock pin. (Fig. 5)

Observe national regulations regarding road transport. Some countries require the use of safety chain when a trailed machine is towed along public roads.

Think of safety while operating the machine

Stop the tractor engine and remove the ignition key prior to carrying out repairs, cleaning, lubrication or maintaining the machine. (Fig. 6)

Safety guards

Make sure all guards are in good order and fitted correctly. Do not attempt to start the machine before ensuring this. (Fig. 7)

Pay particular attention to the plastic guards of the P.T.O. shaft. If damaged they must be replaced. The chain locks of the guards must always be fitted on a suitable place on the tractor and the machine to prevent the outer plastic guards turning.

Hydraulics

Be very careful when dealing with hydraulics. Use eye protection and gloves. Escaping hydraulic oil under pressure might penetrate into the skin and cause serious infection. See a doctor if you have been exposed to injury. (Fig. 8)



Fig. 9

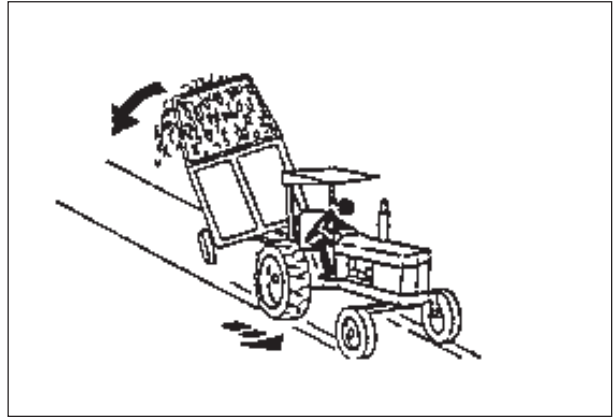

Fig. 10

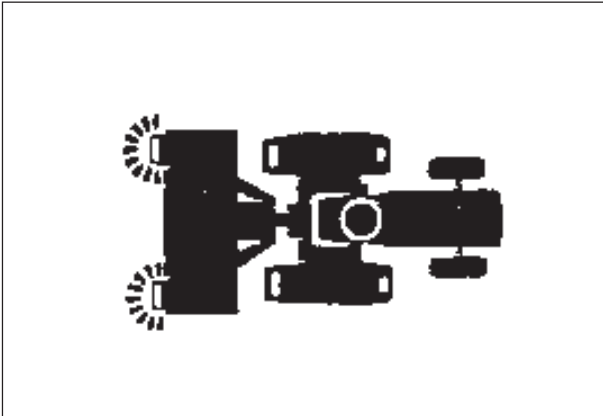

Fig. 11

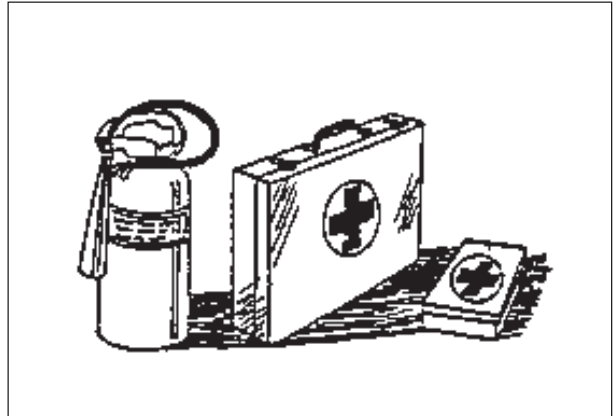

Fig. 12

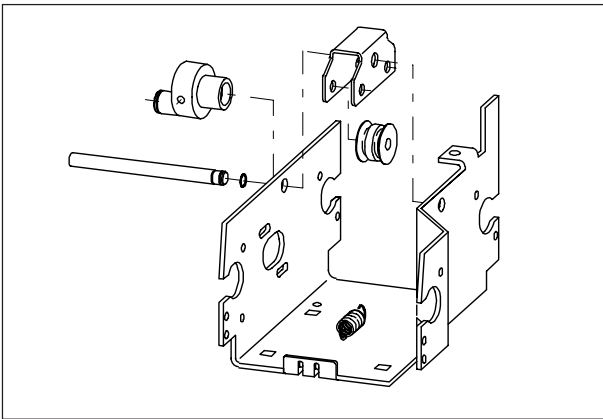

Fig. 13

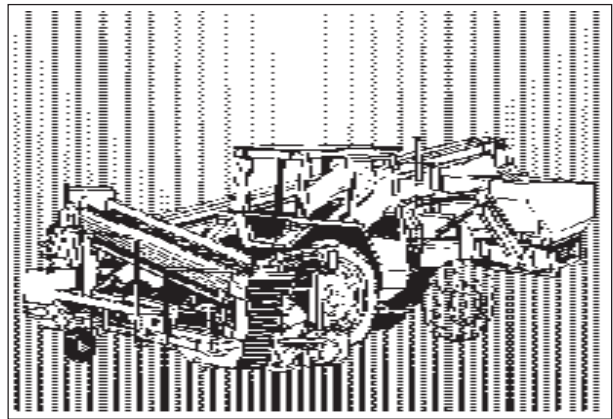

Fig. 14

Take care that nobody is close to the machine when the hydraulic functions are being operated.

When uncoupling machine and when leaving tractor/machine

When uncoupling, all hydraulic functions must be in neutral position. The machine must be lowered to the ground and be safely secured. If the machine have parking chocks they should be used at the wheels. Never allow children to play or stay near agricultural machinery. (Fig. 9)

Drive safely

Beware of your responsibility, - carelessness or negligence may cause serious injury or even death. (Fig. 10)

Prior to transporting the machine along public roads, check wheel bolts and couplings.

Disconnect or lock the hydraulic system.

Drive carefully. Reduce speed when turning and driving on uneven ground. Take care that trailed machine does not start swinging or become unstable.

Please be aware of the danger of overturning when working on slopes and in soft ground.

Reduce load.

Lights

The owner and operator is responsible of providing correct lamps and reflectors on the machine when transported on public roads.

Comply with public regulations. (Fig. 11)

Safety equipment

Always carry first aid equipment on the tractor. Also observe the regulations concerning fire extinguisher. When working with burning materials like hay and straw a fire extinguisher must be available at all times. (Fig. 12)

Spare parts

For safety reasons use only original spare parts. The use of spurious spare parts will cause the Underhaug product guarantee to be invalid. (Fig. 13)

Maintenance

Take care that the machine is properly

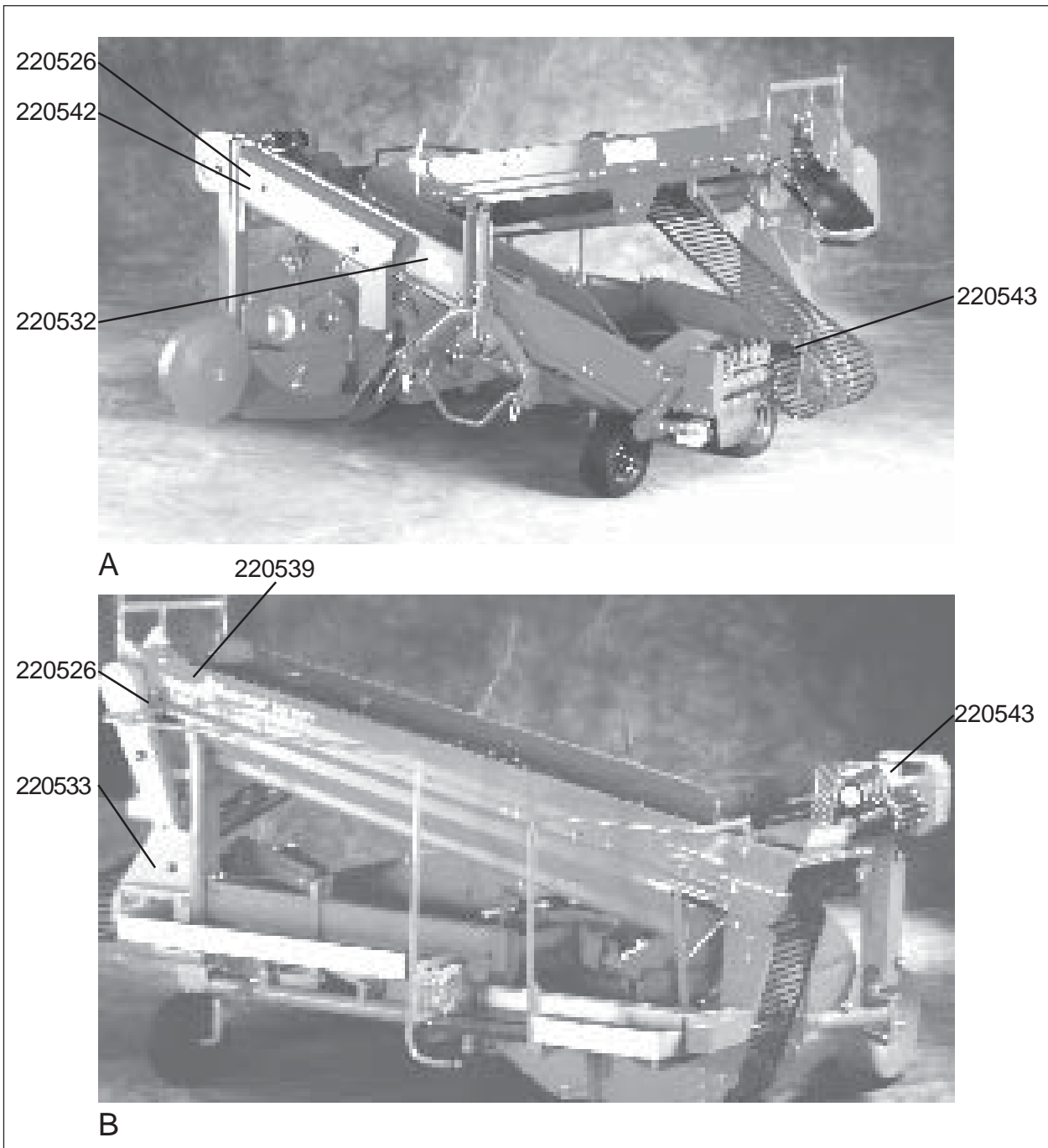

Fig. 15

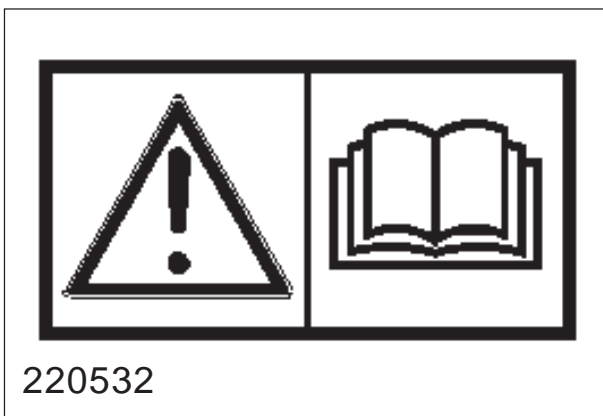

Fig. 16

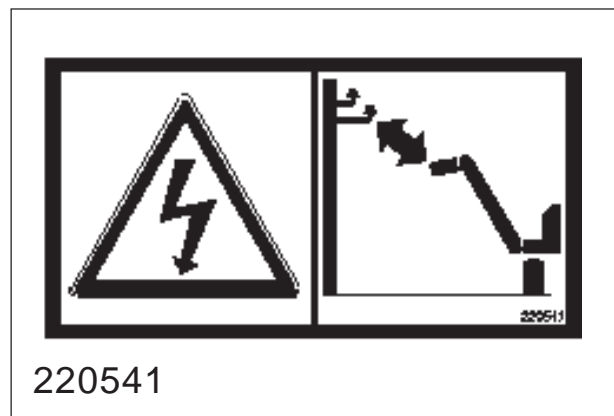



Fig. 17

Supplementary safety instructions for Underhaug Superfaun UN1700 single-row potato harvester

This machine is designed and manufactured for harvesting potatoes or similar tuberous plants. It is designed for manned operation, featuring a work platform for up to 4 persons.

The machine is marked with  warning signs. If the signs are damaged, they must be replaced. Ordering numbers can be seen from the illustrations for this section. See fig. 15 to find where the item in question is located on the machine.

Warning sign 220532 (fig. 16). Caution! Read thoroughly the instruction manual before starting to use the machine and before carrying out adjustment or maintenance.

Warning sign 220542 (fig. 17). Careful when lowering the machine! Keep clear of share and wheel. If work has to be carried out while the machine is in lifted position, supports must be placed under the main frame.

Warning sign 220526 (fig. 18). Fingers can get cut if placed between the drive chain and the chain wheel.

Warning sign 220539 (fig. 19). Fingers can get damaged if placed between the webs.

Warning sign 220543 (fig. 20). Risk of crushing. Keep clear of haulm rollers.

Lifting of machine by crane

Use approved lifting gear only. The weight of the machine can be found under „Technical data“, p. 5.

Be careful! Make sure that no-one is standing under or near the machine while it is being lifted.

Lift the machine using the strap attachments of the accompanying lifting stay which is to be fastened behind the turret on the main frame of the machine. Check that the lifting straps are properly fastened before lifting.

Use the guide strap to keep the machine in position.

Hazard with the use of chemicals

 Always follow the manufacturer's safety precautions regarding the handling of chemicals and fertilizers.

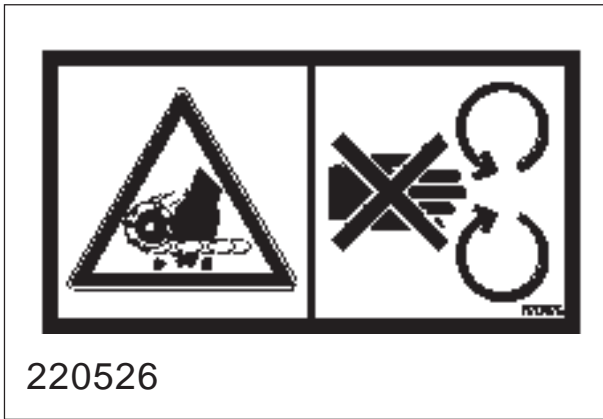

Fig. 18

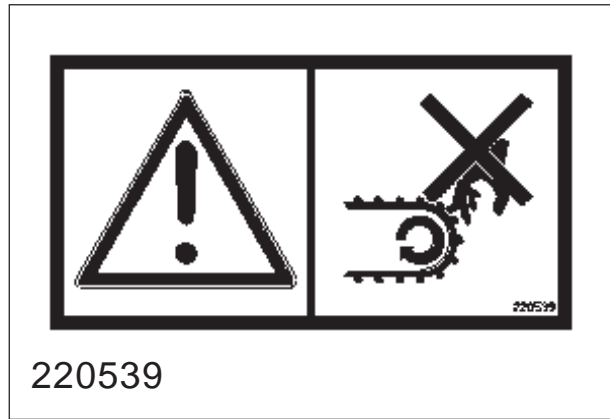

Fig. 19

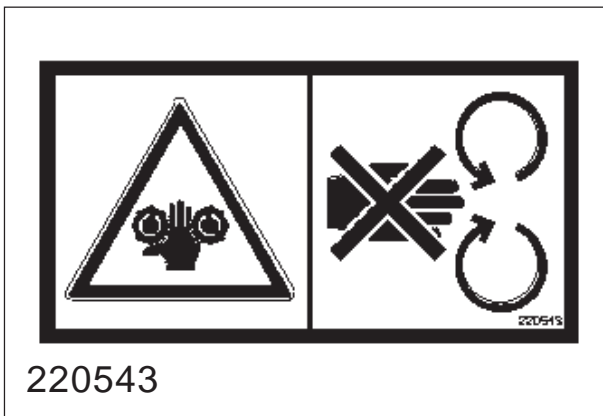

Fig. 20

New machine - caution!

Read the instruction manual. Pay special attention when starting up the machine for the first time. Faulty installation or operation may result in costly repairs and lost income.

Underhaug's product guarantee does not cover damage or injury caused by not complying with the instructions given in the manual.



Pay special attention to this symbol.

It is used to stress important information so as to avoid faulty installation or use.

Also, pay special attention when starting up a new machine:

Check that the machine has been correctly assembled and has not been damaged.

Check that electrical cables and hydraulic hoses are long enough and are placed so as to be able to follow the movements of the machine without being damaged.

Check the linkage to the tractor.

Check that the drive chains are placed correctly on the chain wheels and that they are properly tensioned.

Lubricate the machine as described in section „5.7 Lubrication“.

Check the connection between the harvester frame and the turret.

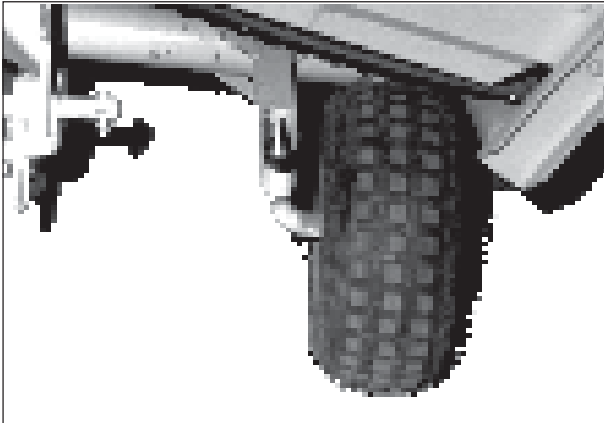

Fig. 21



Fig. 22

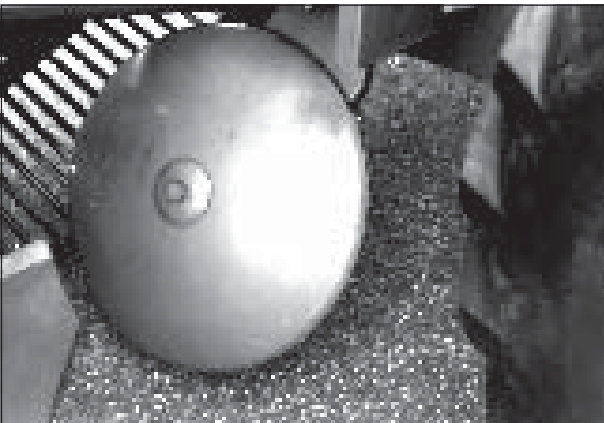

Fig. 23

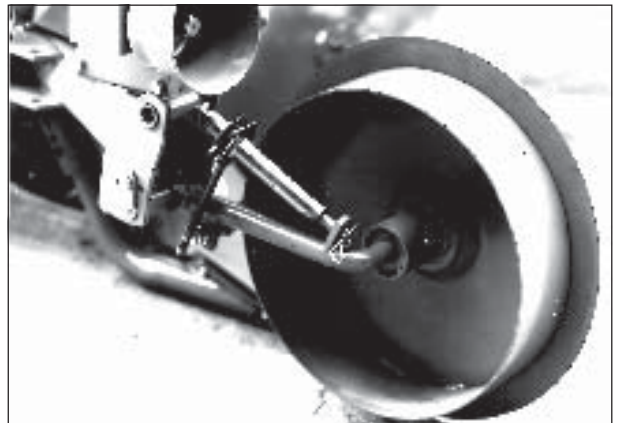

Fig. 24

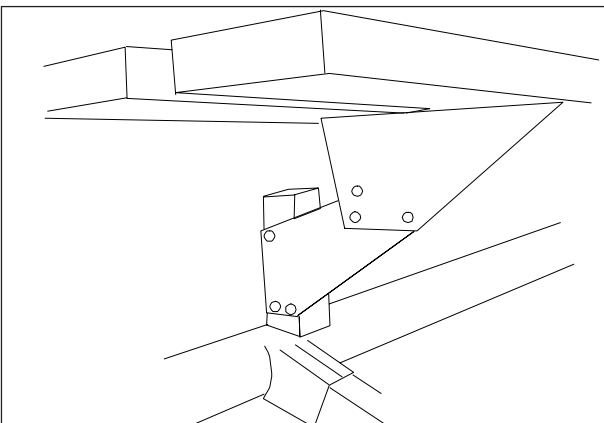

Fig. 25

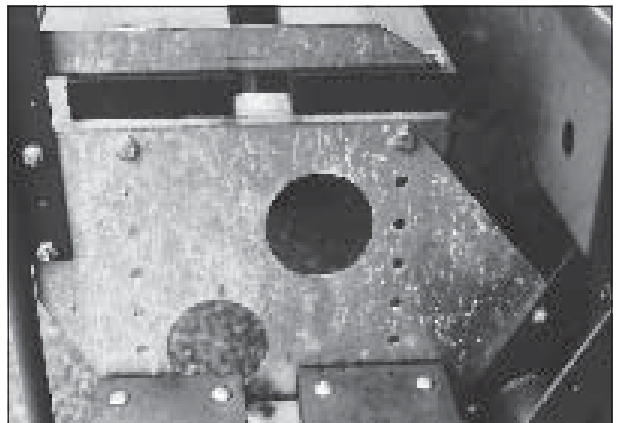

Fig. 26

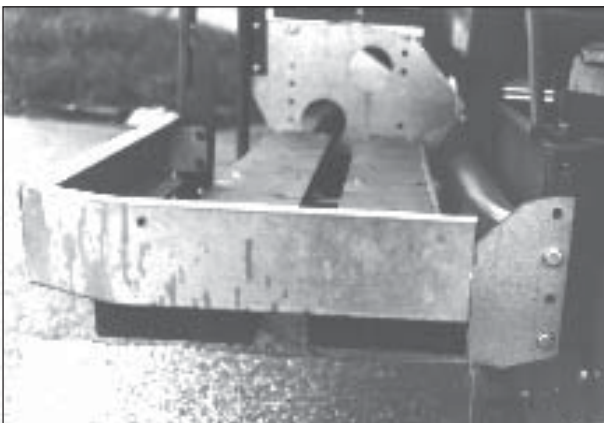

Fig. 27

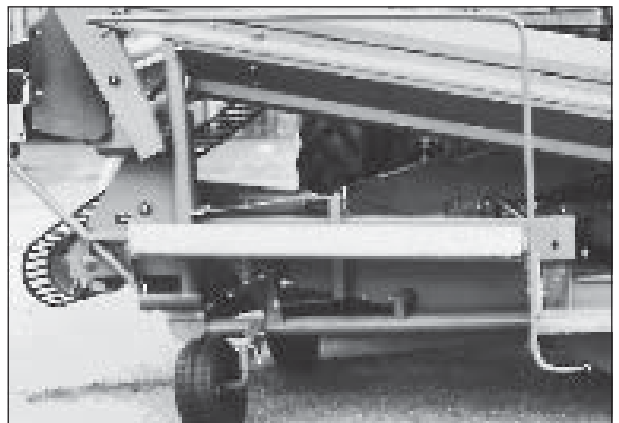

Fig. 28

1. READYING OF NEW MACHINE

1.1 Packing



Remove all packing. Remove all equipment stored in the machine.

1.2 Mounting of wheels

Link the machine to the three-point hitch of the tractor or lift it by means of a crane. NB! Fasten the machine if work has to be carried out underneath it. Remove the transport pallet.

Mount the rear (fig. 21) and front (fig. 22) support wheels at the bottom of the machine, on the left side. Place the wheels so that they are in the same track across the web direction (for harvesting) or in the web direction (for transport).

1.3 Preparation of the lifting unit



a. Check that the share plate is of the right size. A large share (diagonal dimension 45 cm) suits row distances of 75-90 cm (standard share), while the smaller share (diagonal dimension 36 cm) is suitable for row distances of up to 75 cm.

Mount the share plate on the share hook. The share must lie *above* the first web. **If the share presses against the first web, it must be supported by spacing washers between the share hook and the share plate. Otherwise the web may have a strong wearing effect on the rear edge of the share.**



b. Mount the guide discs to the right (seen from the front) of the share (fig. 23). **Retain the guide discs when the screw is fastened, thereby ensuring that the drive mechanism is not exposed to any major impact.**

c. The two digging wheel arms supplied loose are *not* to be mounted. They are used only on extremely light soils where it is difficult to have a smooth progression along the ridge.

d. Mount the roller disc/depth wheel on the outside of the share. Make the distance to the share as small as possible on light soils (fig. 24). On heavy soils the distance can be increased without any risk of losing potatoes between the share and the roller disc. Adjust the distance by placing the spacer sleeves inside or outside the roller disc arm. Turn the attaching sleeve of the stay in the direction that best matches the position of the roller disc.

e. The existing attachment bolt for the roller disc arm guides the roller disc in the desired direction. In the centre position, the roller disc goes straight forward. In the outer positions the roller disc is tilted outwards or inwards, thereby increasing or reducing the distance between the roller disc and the tractor wheel when the machine is working.

1.4 Installation of work platform

Install the left platform attachment on the main frame of the machine (choose between two heights), see fig. 25. Install the centre attachment plate (fig. 26).



Fasten the left (long) part of the platform to the two attachment plates to ensure that it is horizontal.

Fasten the right (short) part of the platform horizontally in the centre attachment plate and in the main frame (fig. 27). Please note the possibility of height adjustment.

Mount the rails (figs. 28 and 29).



Fig. 29

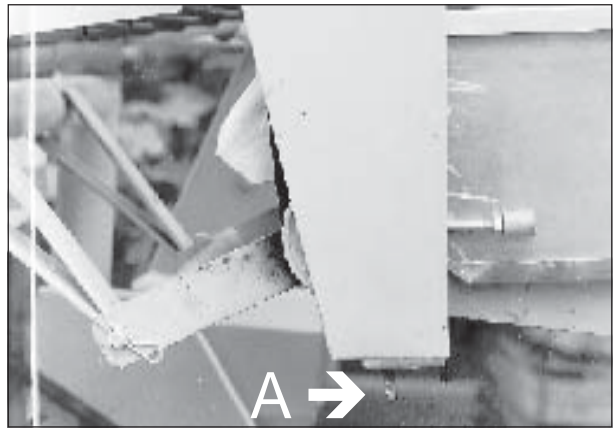

Fig. 32

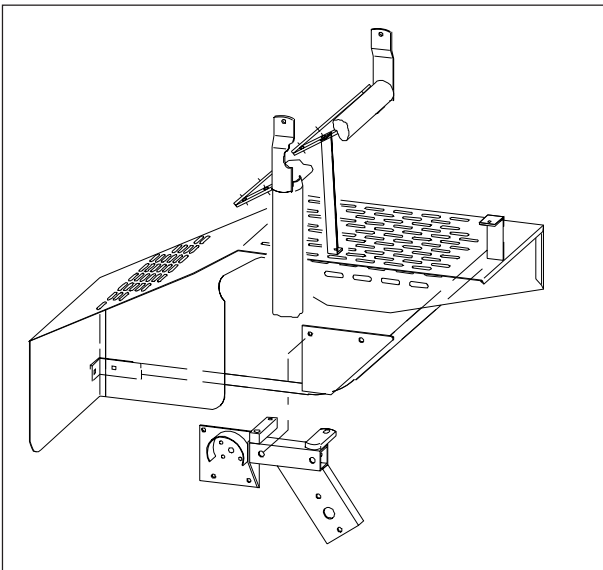

Fig. 30

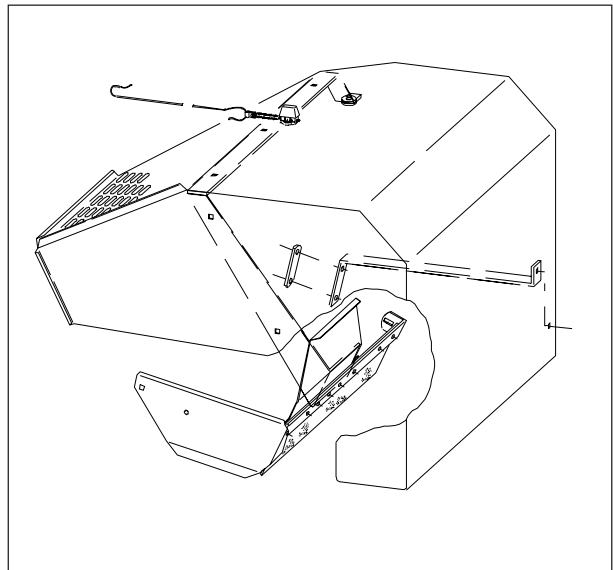

Fig. 31

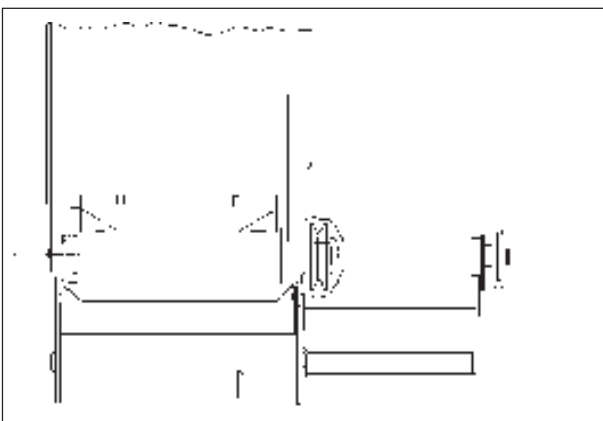

Fig. 33

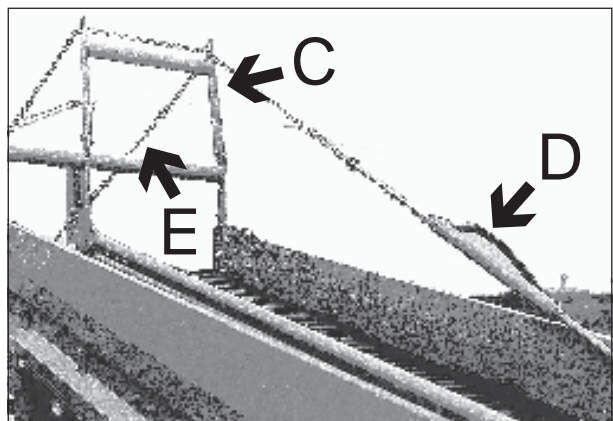

Fig. 34

1.5 Installation of protection shields above haulm roller

Mount the protection shield above the bottom haulm roller, see fig. 30.

Mount the protection shield above the top haulm roller as shown in fig. 31.

1.6 Readying of conveyor

1.6.1 Trailed conveyor

For picking out rubbish from potatoes on the picking table (normal position):

Mount the conveyor at the front attachment points under the end of the picking table.

Mount the belt disc at the front end of the drive shaft of the picking web, place the V-belt and return the belt shield to its original position.

Tighten the V-belt with screw A. See fig. 32.

For picking out potatoes from the rubbish on the picking table (extremely difficult harvesting conditions):

Mount drive shaft extender B on the conveyor (fig. 33). Then fasten the conveyor to the rear attachments under the picking table. Mount the belt disc, the V-belt and the belt shield as shown in fig. 32.

For both alternatives:

Mount lifting bracket C and cylinder D, see fig. 34. Adjust the height roughly by means of chain E. Fine adjustment of the loading height during the work is carried out using the cylinder.

Mount the fall damper at the end of the elevator. See fig. 35. Take cord F to the platform rail to remote-control the bottom part of the fall damper.

Check that the conveyor belt runs at the centre of the conveyor. Adjust by means of screw G (fig. 32) and the tightening screws in the upper end of the conveyor while the conveyor is moving.

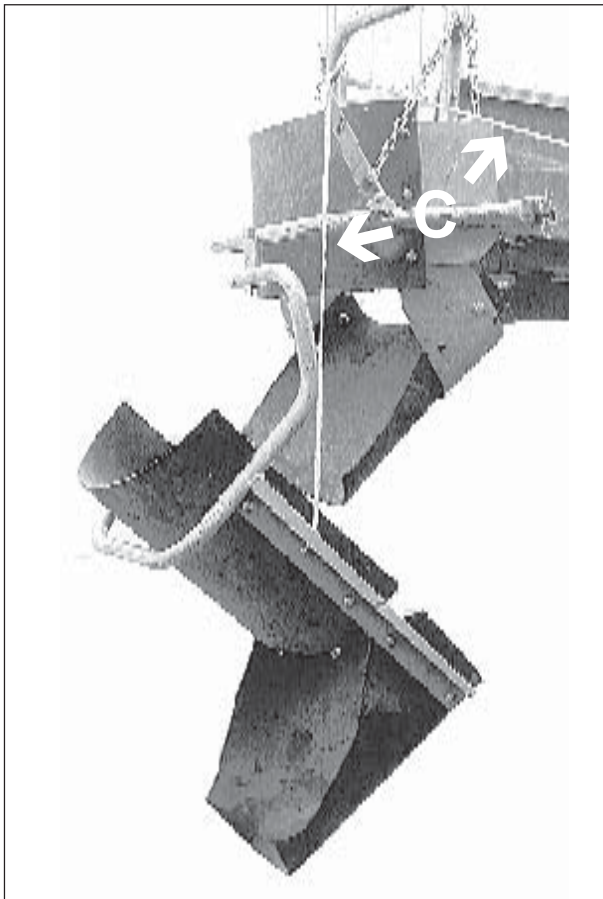

Fig. 35

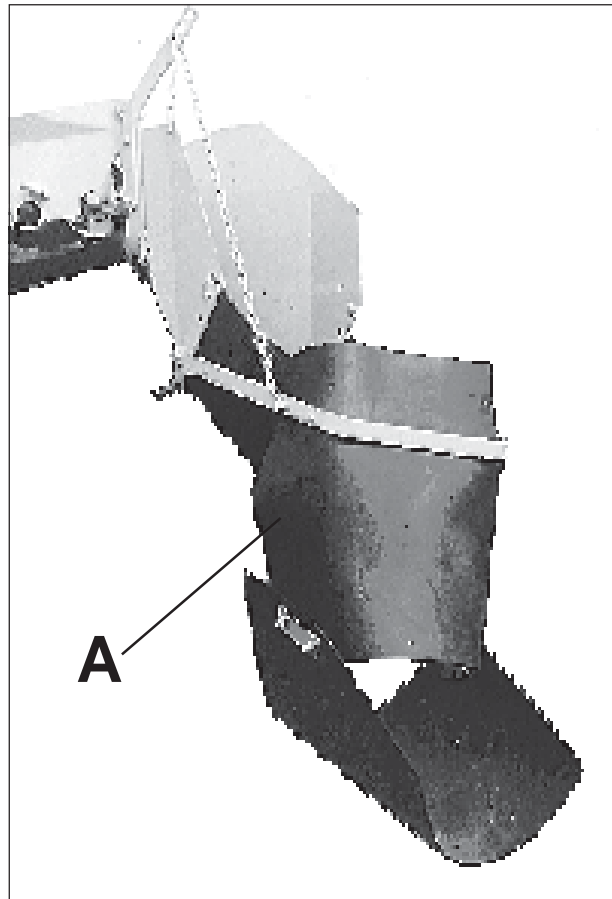

Fig. 36



Fig. 37

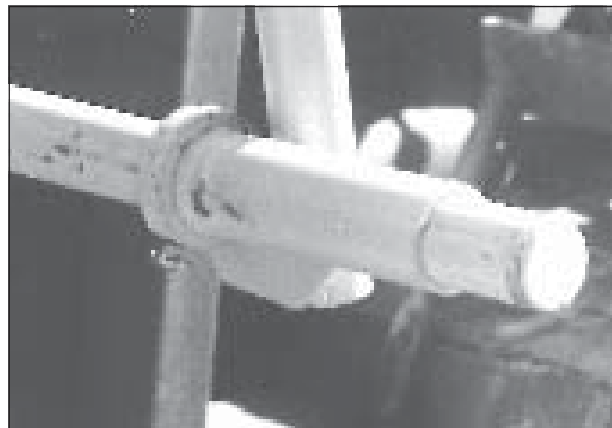

Fig. 38

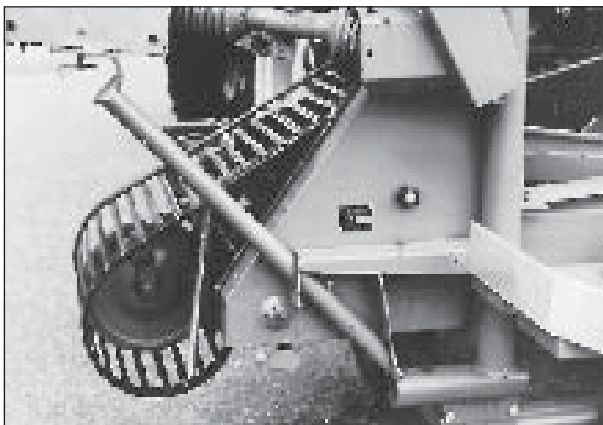

Fig. 39

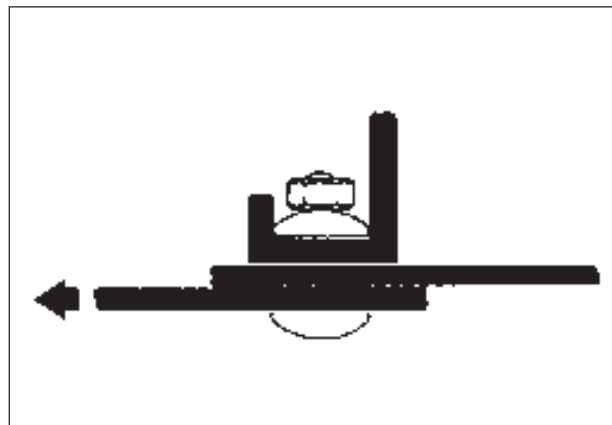

Fig. 40

1.6.2 Side conveyor

The side conveyor is to be readied after the pick-up equipment at the front of the tractor has been mounted. This is done to ensure the optimum length adjustment of the conveyor. If a fall damper has been installed at the front, the length must be adjusted to ensure optimum filling into large boxes or a tank.

Side conveyor attachment:

Rigid type:

Used together with a single box form.

Normally, mount *as far back* on the front-end loader arm as possible. See fig. 37. This enables adjustment of the fall height from the end of the conveyor. *If the tank/big box is to be lifted up high, the side conveyor attachment must be mounted at the front to ensure that the conveyor follows the movements of the front-end loader.*

Make sure that the attachment plates do not touch rigid parts of the loader when raising/lowering.

Lock the vertical rod with the lock-ring, with the screw through the groove in the attachment sleeve, see fig. 38. Place the sleeve in such a position that the screw is at the centre of the track, thereby enabling the attachment to swivel in the direction of the conveyor.

Fasten the carrier frame to the side conveyor. Lock it with the screws.

Pending type:

Used when harvesting with a tank or a double box fork.

To be fastened like the rigid type, see above.

Connect the electric actuator to the tractor battery. Black cable to minus; blue cable to +12V.

Side conveyor:

Mount the rear attachment post. See fig. 39.

Slide the front part into the rear part until the assembly has the correct length. If the standard side conveyor is too short, a 70cm extension set can be supplied (order no. 81701). Connect using screws and mount the carrier rollers at regular intervals over the length of the conveyor. Ensure that the return rollers are spaced equally.

Place the conveyor belt with the lowest edge of the carriers at the front (to ensure that they move easily across the return rollers). After the length of the conveyor has been determined, the belt lock is to be mounted as shown in fig. 40. Cut off excess belt length. Remaining belt locks can be used if the conveyor is to be extended.

Potato channel for side conveyor:

See fig. 36. Use the bottom part A (the fall damper) only if a box fork is used, too. Adjust the angle of the fall damper by means of chain B.

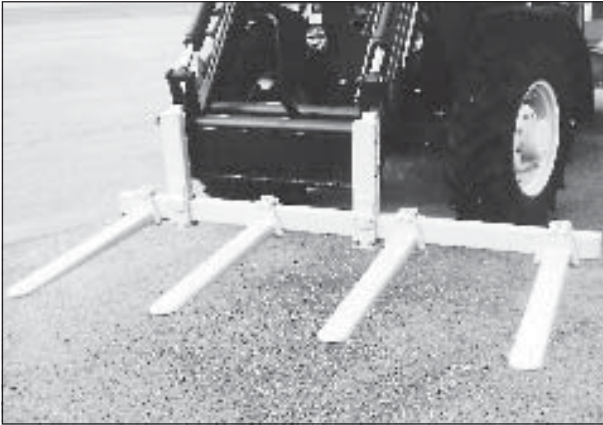

Fig. 41

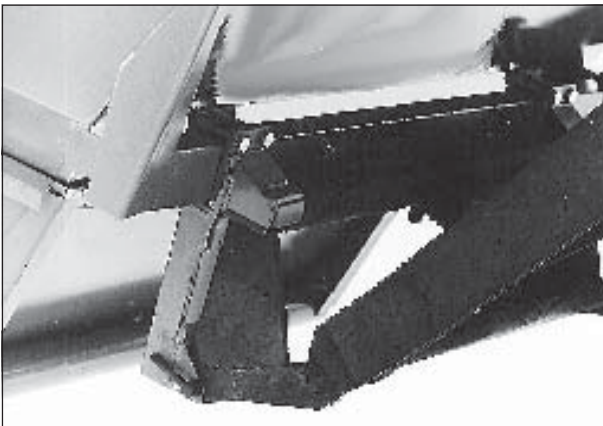

Fig. 42

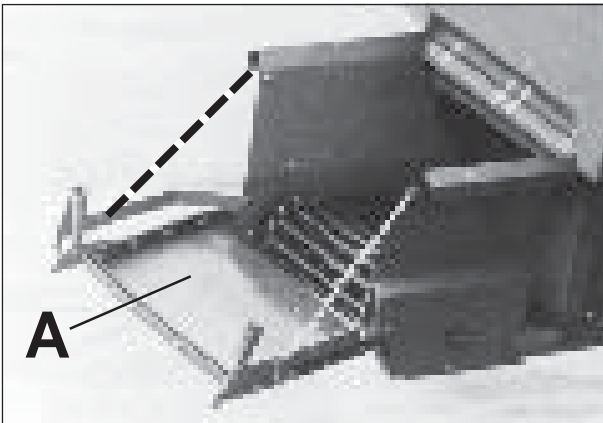

Fig. 43

1.7 Preparing the pick-up unit

1.7.1 Bagging platform

See separate mounting instructions.

1.7.2 Box fork

See fig. 41. Mount the fork attachments by means of connectors adapted to the front-end loader. If harvesting is into two boxes, the fork must be moved to the left to allow the side conveyor to reach into the right-hand box. If the right-hand part is used only for carrying empty boxes, the fork can be mounted to ensure that the left-hand box reaches the centre line of the tractor.

1.7.3 Tank with hatch

Mount the tank attachments by means of connectors adapted to the front-end loader. See fig. 42.

1.7.4 Tank with moving floor

Mount the tank attachments by means of connectors adapted to the front-end loader. See fig. 42. Mount the fall damper in the tank discharge (fig. 43/A). Adjust the angle by means of chain B.

1.8 Position of the turret

The turret has two positions. In wide row distances, or if broad wheels are used on the tractor, i.e. when the pick-up unit of the machine has to move far away from the tractor centre line, the turret must be fastened in the left-hand position. This keeps the roller disc and tractors wheels from damaging the potatoes in the ridge.

NB! Fasten the attachment bolts well. Remember to re-fasten at regular intervals.

1.9 Preparing of accessories

1.9.1 Stone hopper

See separate mounting instructions.

1.9.2 Sorter for small potatoes

See separate mounting instructions.

1.9.3 Haulm cutter

See separate mounting instructions.

1.9.4 Superstructure

See separate mounting instructions.

1.9.5 Alarm

See separate mounting instructions.

2. TRACTOR REQUIREMENTS

Hydraulic lifting capacity:

Model	UN1701	UN1720	UN1723	UN1724	UN1725
Minimum	1,600kg	1,500kg	1,500kg	1,500kg	1,500kg

Power requirement:

Model	UN1701	UN1720	UN1723	UN1724	UN1725
Minimum	50HP (37kW)	50HP (37kW)	50HP** (37kW)	50HP** (37kW)	50HP** (37kW)

** Recommended: 4-wheel drive and min. 65HP (48kW) for full utilization of the lifting capacity

Electrical connection

(only for machines with swivelling side conveyor attachment or alarm):

12 V voltage.

Three-point linkage:

Category 2.

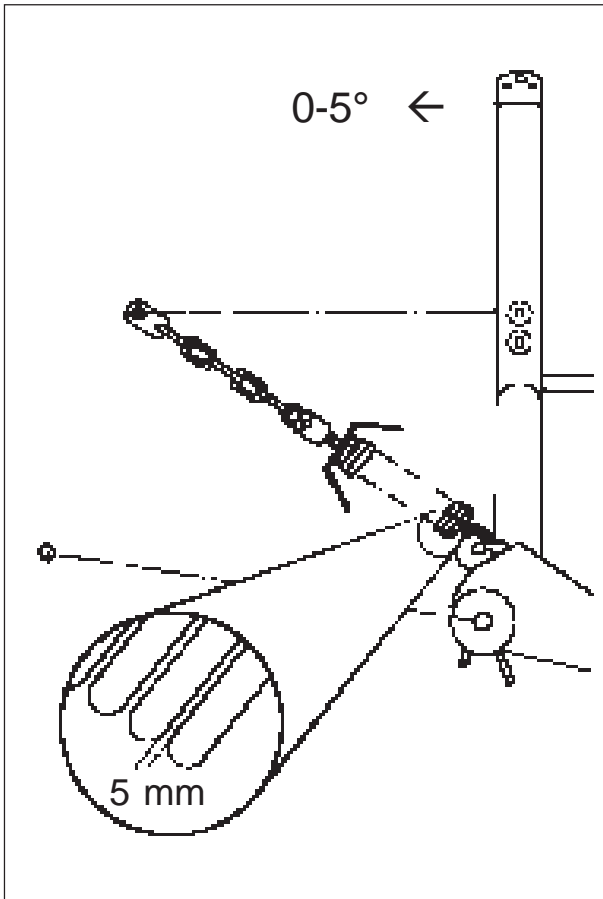

Fig. 44

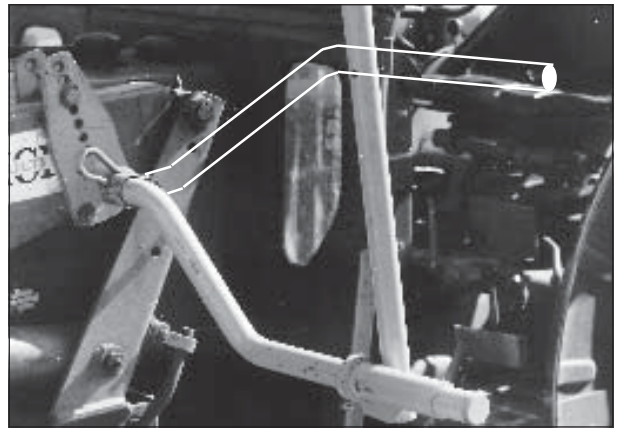

Fig. 46

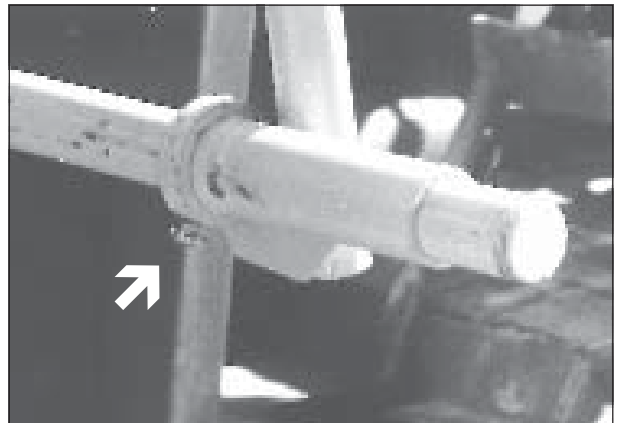

Fig. 47

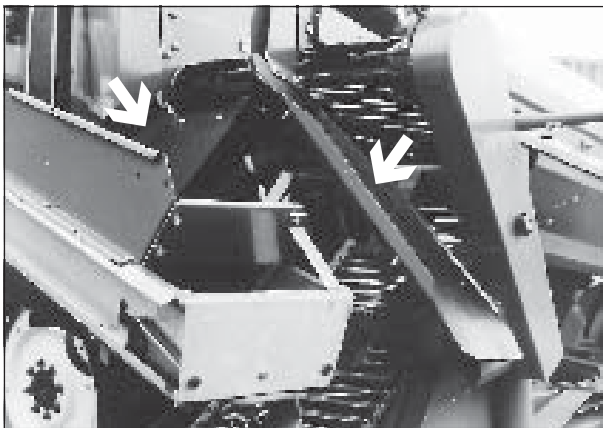

Fig. 48

3. LINKAGE TO TRACTOR

3.1 Basic machine

- a. The tractor drawbars must be levelled. The stabilizing stays are not required.
- b. Mount the pulling shaft on the tractor drawbars; then pull and lift until the lock-pins find the right position. Use the attachment bolt for the chains for the suspension springs that best match the tractor in question. This bolt and the suspension chains are used as top stay bolts or fastened just under the top stay bolt.
- c. Connect the top stay and adjust the length to ensure that the machine turret is slightly inclined *forwards*. See fig. 44. This is important for the machine to work smoothly and in order to avoid damage to the pick-up unit and the first web. When the top stay and the drawbars are as much in parallel as possible, the tractor has the maximum lifting capacity.
- d. Lifting straps for haulm cutters, if used, are fastened to the top stay bolt on the tractor.
- e. Connect the power transmission shaft and fasten the safety links for the protection sleeves. In case of a first installation, or installation on another tractor other than the one for which the original adaptation was made, the length of the shaft has to be checked. See instructions from the shaft manufacturer.
- f. Lift the machine. Fasten the suspension springs to the harvester turret. Normally, the outer hooks are used. If there is a need to shift the machine to the left or to the right (for adjustment of the distance between tractor wheel and share rollers), the springs must be fastened unsymmetrically and tightened differently. Connect spring and chain and tighten to leave approx. 5mm clearance between the spring windings when the machine is standing on the ground. See fig. 44. **NB! The main purpose of the suspension springs is to reduce the pressure on the roller disc.**
- g. If a driver's alarm is used, it must be connected to a fused 12 volt supply.
- h. Use the digging wheel arms as little as possible. On a new machine, two are mounted and two more come separately with the machine. In the majority of conditions, the

result is best if the digging wheel arms are not used. On extremely light soils, they can provide a smoother flow across the share. On extremely heavy soils, they can help to break up the ridge. **NB! The digging wheel arms may cause damage to the potatoes.**

3.2 Trailed conveyor

To be connected as described in section 1.6.1. The hydraulic hose is to be connected to a *single-acting* terminal on the tractor.

3.3 Front-mounted pick-up unit

Tank, bagging platform or box fork are to be fastened to the tractor. Make sure to secure the unit by using the front-end loader locking bolts or the units own fittings. Check the attachment bolts.

3.4 Side conveyor

For machine with tank or box fork:

Connect the side conveyor attachment to the bracket that has been attached to the front-end loader arm. The horizontal attachment arm can be placed in a high or a low position (turn the attachment 180°), depending on the height requirement of the side conveyor end. See fig. 46. Ensure that the vertical post can swivel freely to accommodate the movements of the side conveyor when the harvester is raised and lowered on the hydraulics. See fig. 47. Connect the actuator to the tractor battery circuit (own battery cable).

Connect the side conveyor to the attachment arm on the harvester. At the same time, connect the power transmission shaft and fasten the safety link for the protection sleeves. Lift the front end and fasten the conveyor to the attachment bar on the bagging platform or to the side conveyor attachment on the front-end loader. Check that the conveyor has been properly secured. Adjust for height until the working height for the bag discharge/fall height to the box or tank is satisfactory.

Position the bag discharge unit or the potato channel/fall damper at the front end of the side conveyor.

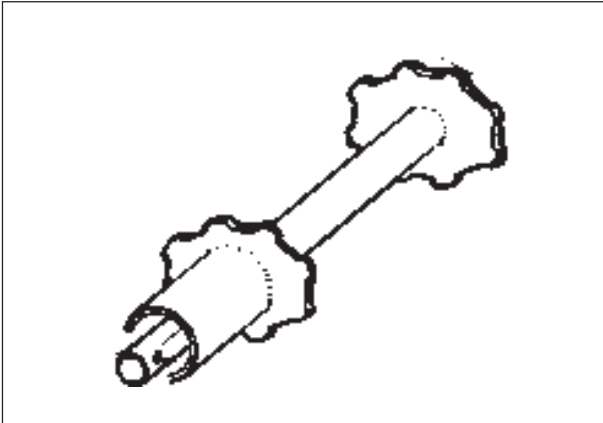

Fig. 49



Fig. 50

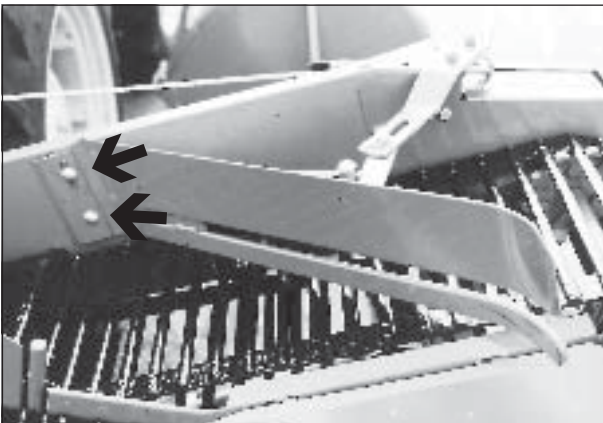

Fig. 51

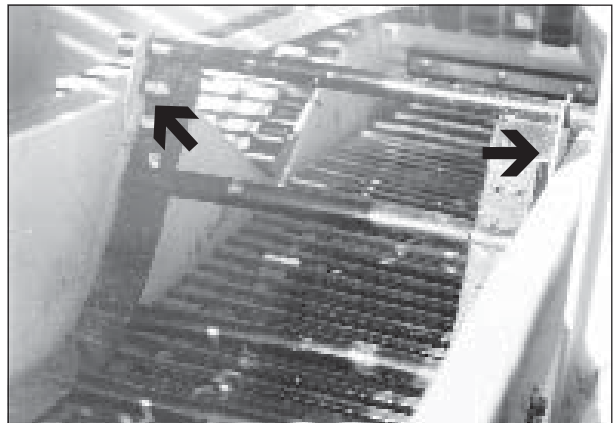

Fig. 52

Position the potato channel and the waste channel at the transition point from picking table to side conveyor. If residue has to be picked from the potatoes (normal method), the waste channel is placed at the rear discharge end of the picking table, and the related potato channel at the front discharge end. See fig. 48. If the potatoes are to be picked out of the residue (extreme conditions), a small potato channel is to be installed at the rear discharge end. At the front discharge end the upper waste channel is to be mounted, which guides the waste into the side conveyor and down on the bottom waste channel. This is to be installed on the attachment pins under the picking table. See fig. 49.

4. MACHINE OPERATION

4.1 Machine RPM

The recommended power take-off rpm is 250-350 rpm/min. A low rpm value normally results in less damage to the crop.

4.2 Depth adjustment

Adjust the depth with the roller disc. Normally, the share must operate down just under the potatoes. On light, stone-free and clod-free land, it is worth going in deeper to get out more soil. This protects the potatoes on the first web. If there are a lot of stones and/or clods in the soil, it has to be assessed whether to set the share at a depth where some of the potatoes will be cut by the share. This can be more economical than having to remove large quantities of stones and clods brought into the machine if the share digs in deeper.

4.3 Side positioning of the pick-up unit

There must be enough clearance between the tractor wheel and the roller disc for the potatoes in the ridge not to be squeezed. Adjust the distance by the direction of the roller disc, the position of the turret and the position and tightening of the suspension springs, see sections 1.3.e and 3.1.

4.4 Digging wheel arms

Adjust the number to the current need. See section 3.1, item h.

4.5 Soil separation

Most of the soil is to be separated out on the first web. This also ensures the best haulm separation. Adjust by the relation between flow speed and rpm. Use hopper agitation on the first and second web.

Never use higher rpm or more agitation than required. This would unnecessarily *increase the risk of damage to the crop*.

4.5.1 Agitation of the first web

The two bottom bearer rollers can be replaced by the agitation rollers supplied. See fig. 49. **The upper roller (under the sloping shield) is *not* to be replaced by a agitation roller**

4.5.2 Agitation of intermediate web

Adjust by means of the lever at the front edge of the picking table. Three positions.

4.5.3 Sloping shields

Principally, the sloping shields on the first and intermediate webs are to be placed in the highest possible position with respect to the size of the potatoes. A large aperture under the sloping shield makes for good separation of soil, stones and clods. The separation of haulm is also improved, because the the haulm gets over to the haulm rollers more easily. The sloping shields can be placed at a sharp angle to ensure that the potatoes do not come into close contact with the haulm rollers, but are taken directly down to the next web.

Make sure that the sloping shields are parallel to the web, or have increasing clearance towards the discharge point. On the first sloping shield, adjust this by means of the attachment screws between the shield plate and the square tube, fig. 50. On other sloping shields, adjustment is made at the front side plate attachment point after adjustment of height, fig. 51.

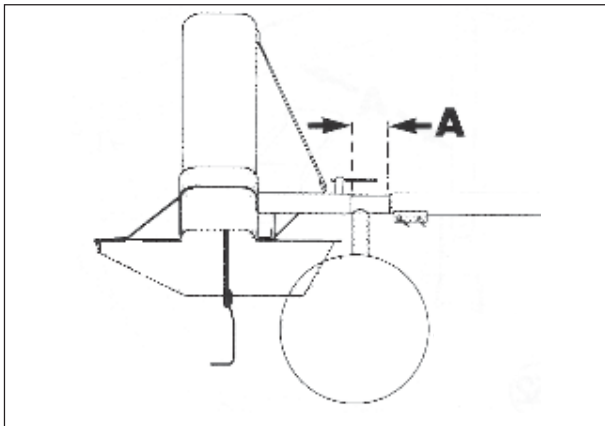

Fig. 53

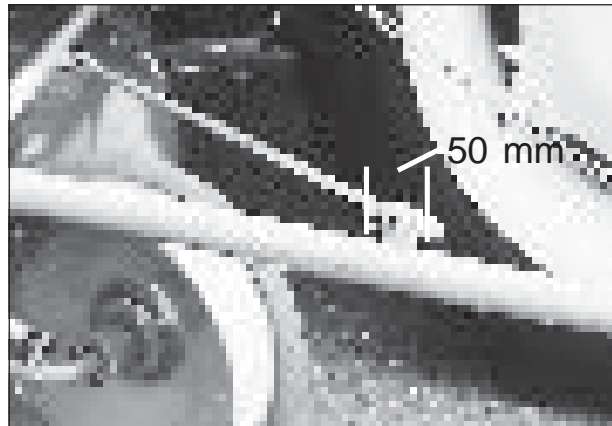

Fig. 54



Fig. 55

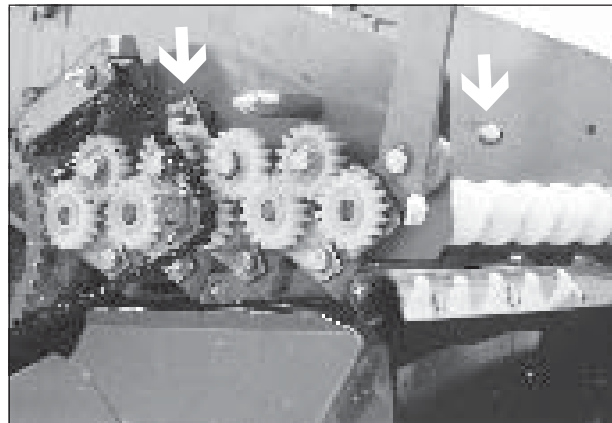

Fig. 56

4.5.4 Clod crusher web

To be mounted on the intermediate web.
Attach to the brackets to the left of the turret,
fig. 52.

Only for use when the soil is difficult to separate,
or if the clods are very soft. Can also help to
remove potatoes stuck on the haulm.

*Use of the clod crusher web involves a risk of
damage to the crop.*

4.6 Haulm separation

Superfaun works best with relatively small quantities of haulm. That is why the use of a haulm crusher (separate or integrated in the machine) or early chemical/thermal haulm withering is preferable.

4.6.1 Adjustment of machine haulm cutter

Position the cutter head to ensure that cut-offs are blown under the tractor. Be sure to have sufficient overlap on the drive shaft. The distance A (fig. 53) must be max. 50cm.

Place the spring-loaded pins in the stabilizing stays of the haulm cutter, thereby ensuring that the cutter moves freely when idle-running within the row to be harvested and with sufficient room for moving to the sides (min. 50mm distance between the spring-loaded pins), fig. 54.

Adjust the depth to ensure that there is no risk involved for potatoes and discs (contact with stones).

4.6.2 Adjustment of haulm roller

If the potatoes remain stuck to the haulm, the pressure on the first double haulm roller must be increased. The normal height to the upper edge of the spring-loaded cup must be approx. 130mm.

Read section 4.5.3. Make sure that the position of the sloping shields is optimal.

NB! The haulm roller rods must intersect. If that is not the case, the top roller must be taken out and turned to the right before being re-installed.

4.7 Picking table speed

Two speeds, see double chain wheel, fig. 55.

4.8 Height of operator platform

The height on the right and left part of the platform can be adjusted. See section 1.4.

4.9 Variation of picking direction

See sections 1.6.1 and 3.4.

4.10 Changing of picking grade, sorting of small potatoes

Loosen the locking bolt for the bracket above the picking table and adjust it in or out until the desired aperture is obtained, see fig. 56.

4.11 Emptying of stone box

Operate the lock by foot. The hatch returns automatically.

If emptying is carried out in the field, it is to be recommended to let the stones lie in whole rows of their own. This makes it easier to pick up the stones for removal.

4.12 Bearer wheel position

The bearer wheels can be turned 180° by removing the bolt through the wheel spindle and turning it round.

The bearer wheels should correspond to the row distance and the track width of the tractor.

4.13 Road transport

In case of transport on public roads and narrow farm roads the machine can be trailed after the tractor. Turn the bearer wheels 90° and lock them. Mount the transport shaft in the right-hand end of the machine. Place the conveyor and the haulm cutter, if used, on the machine. Attach the pulling shaft on the tractor drawbars and connect the transport shaft to the pulling shaft.



Fig. 57

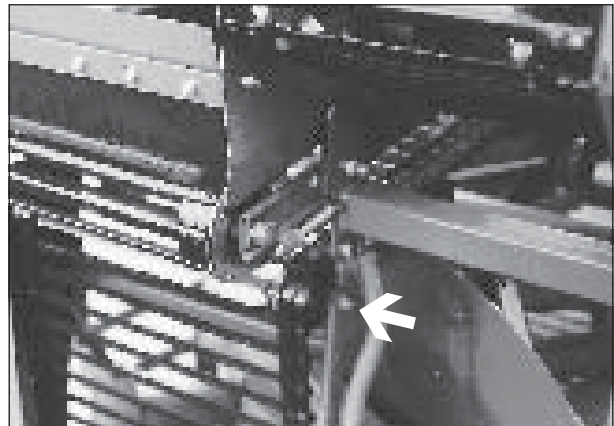

Fig. 58

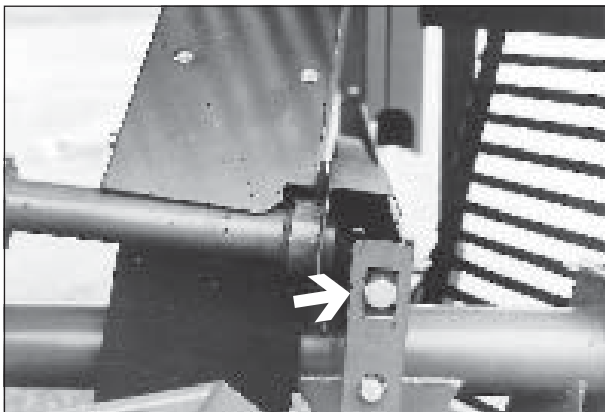

Fig. 59

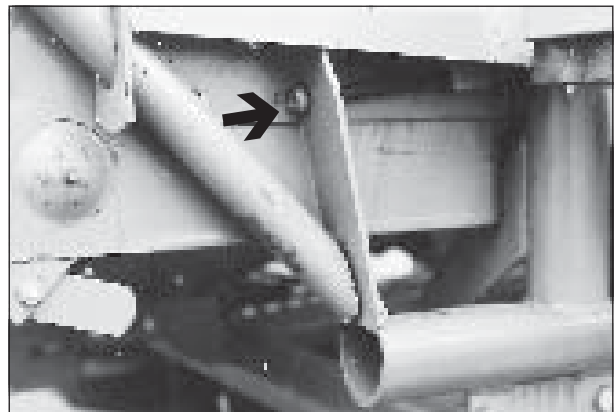

Fig. 60

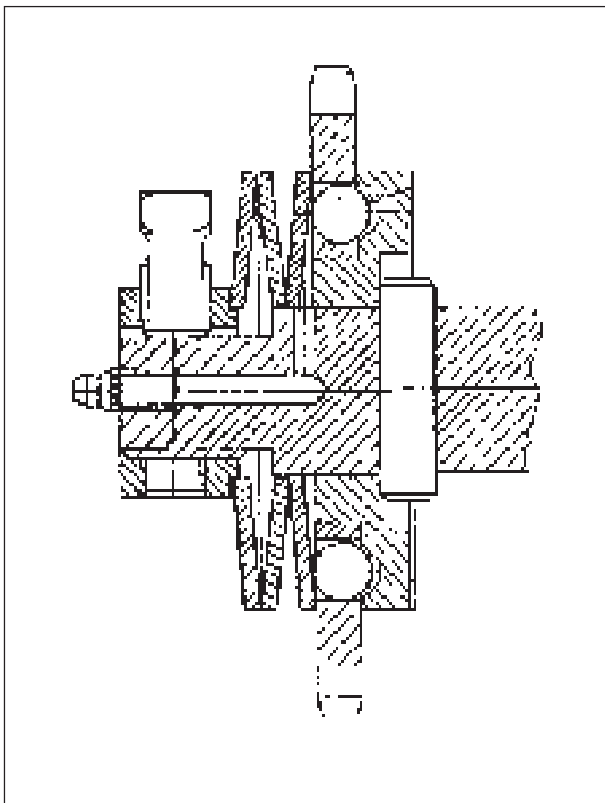

Fig. 61

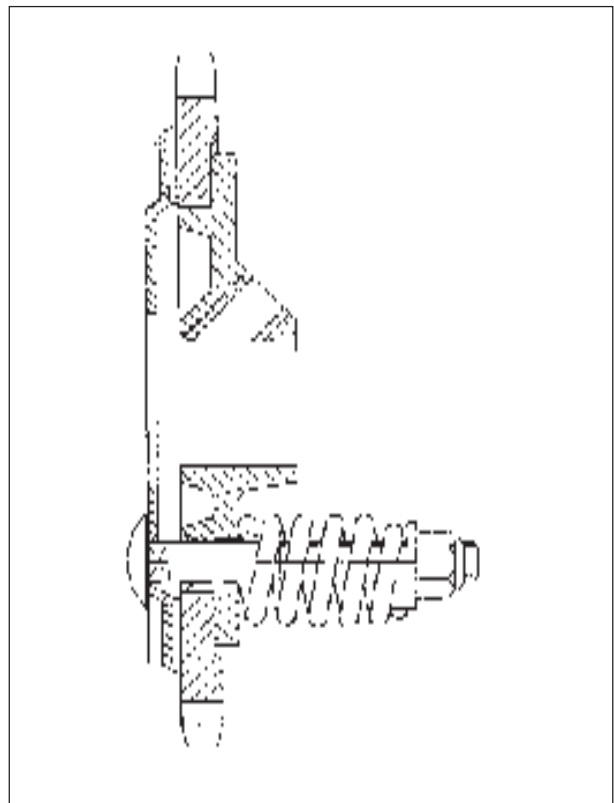

Fig. 62

5. MAINTENANCE

5.1 Tyre pressure

Recommended tyre pressure LP190-8". 4.0 kp/cm².

5.2 Web tension

First web:

Operated by means of the rear tightening screw on the frame bracket on the right-hand side of the machine. The tightening screw at the front upperweb roller is subsequently adjusted to ensure that unnecessary loads on the tightening bracket can be avoided. Approx. 5 cm web sagging between the return rollers is recommended.

If the first web moves unevenly (touches one or several of the round guide plates), the web is centered by moving the lower, rear attachment point for the tightening bracket (3 attachment points, fig. 57) or the upper, front web roller on the tightening bracket (oblong hole, fig. 58). If the web touches the guide plates at the rear edge of the web, move the rear attachment point outwards or the front web roller inwards. If the front guide plates are touched, adjust the other way round. Such adjustment should be checked with correct web tension and both in unloaded and loaded condition.

NB! In order to extend the life of the first web, it is important to turn around the web before the webs have been worn too much by the web drive (the sides) and the web turning wheel (near the centre). Turning the web makes it wear more evenly.

Intermediate web:

Tightening rollers at both sides in the lower end of the web. Approx. 5 cm belt sagging between the return rollers is recommended.

If the belt moves unevenly on the drive shaft (uneven wear on the web drive/movement of the tines), adjust the position of the attachment bracket for the drive shaft (oblong attachment hole).

Picking web:

Tightening rollers at both sides in the lower part of the web. Approx. 5 cm web sagging between return rollers is recommended.

Trailed conveyor:

Tightening screws on both sides of the upper turning roller. Adjust the load. Make sure that the rubber web is centered between the plates. Check with the machine in operation. Also adjust the drive shaft.

Side conveyor:

Tightening screws on both sides of the rear turning roller. Adjust the load. Make sure that the rubber web is centered between the plates. Check with the machine in operation. Also adjust the front turning roller.

5.3 Chain/V-belt tension

Main operation: Automatic

Guide disc:	Automatic
Digging wheel:	Tightening screw on rear chain wheel (fig. 59)
First web:	Tightening screw at drive shaft (fig. 60)
Intermediate web:	Lower edge of chain shield
Picking web:	Automatic V-belt, trailed conveyor: Tightening screw lower edge V-belt shield

5.4 Safety clutches

Check the function of these clutches before starting the season and when the season ends. If the machine is unused for long periods, carry out extra inspection before starting up.

Main operation: Pre-set torque 600Nm.









Digging wheel: Placed on the intermediate shaft.

Pre-set torque 360Nm.

First web/picking web:

Placed at the rear end of the intermediate shaft (at the entry to the platform). Pre-set torque approx. 160Nm. Tighten by loosening the screw in the tightening nut and turn the nut 1/4 to 1/2 turns to the right. Move the screw to keep it on the recessed plate on the shaft.

After dismounting it must be ensured that the disc springs are in the right position and

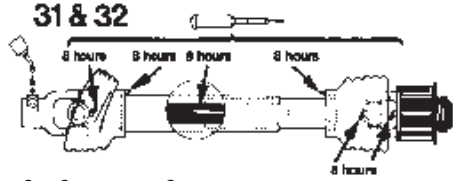
Interval		8h		40h		Interval		8h		40h	
Pos.	*)					Pos.	*)				
1	r				<input type="checkbox"/>	21	r				<input type="checkbox"/>
2					<input type="checkbox"/>	22	f				<input type="checkbox"/>
3					<input type="checkbox"/>	23	f				<input type="checkbox"/>
4					<input type="checkbox"/>	24	r				<input type="checkbox"/>
5					<input type="checkbox"/>	25	r				<input type="checkbox"/>
6					<input type="checkbox"/>	26	f				<input type="checkbox"/>
7	f				<input type="checkbox"/>	<p>31 & 32</p>  <p>*) f - foran - front - vorn - avant r - bak - rear - hinten - derrière</p>					
8	f				<input type="checkbox"/>						
9					<input type="checkbox"/>						
10	r		<input type="checkbox"/>		<input type="checkbox"/>						
11	f				<input type="checkbox"/>						
12	f				<input type="checkbox"/>						
13	f				<input type="checkbox"/>						
14	r				<input type="checkbox"/>						

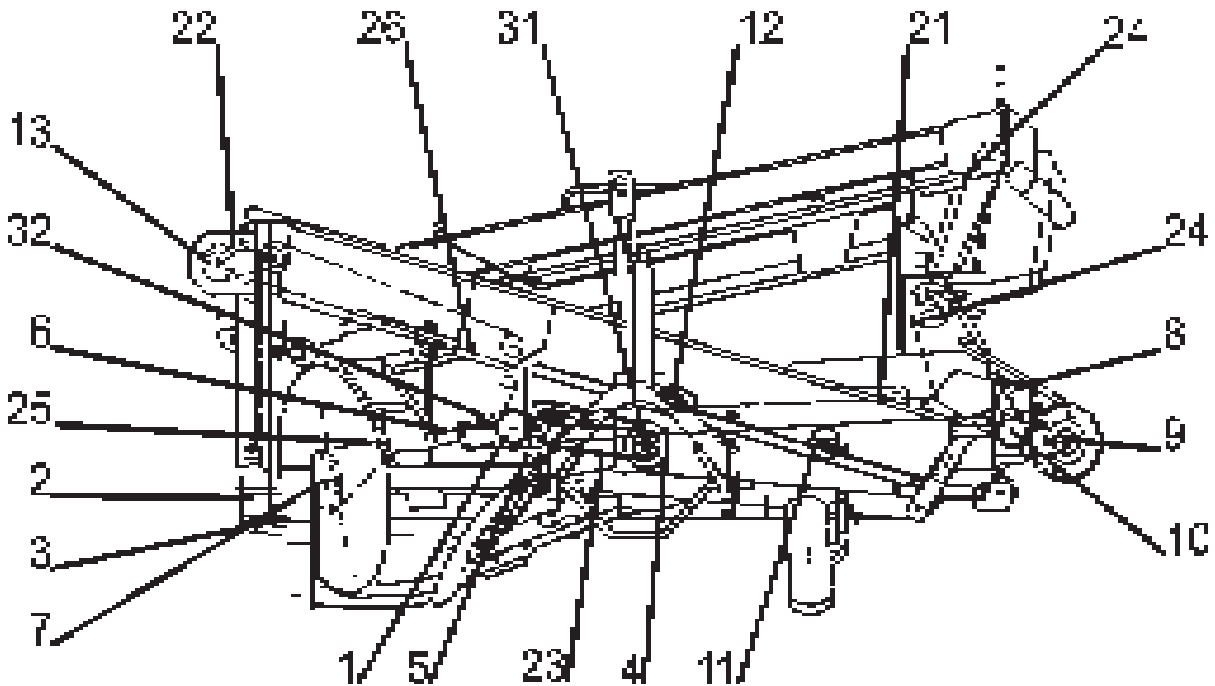

move in over the drive shaft. See fig. 61.
Faulty mounting may lead to coupling failure.

Intermediate web:

Placed on the drive shaft at the upper end of the intermediate web. Pre-set torque 140Nm. Adjust by tightening or slacking the three springs. See fig. 62.

5.5 Adjustment of guide disc

Wear reduces the diameter on the guide disc at the share. To avoid loss of potatoes between web and guide disc, the guide disc must be moved down towards the web. Loosen the screws at the back of the attachment plate. If necessary, extend the drive chain.

NB! If the guide discs are placed too low, the first web can be damaged when the machine is placed on the top of a ridge in such a way that the web is pressed up towards the guide discs.

5.6 Cleaning

Remove soil and plant residue before putting the machine away after use. Apply an anti-corrosion agent to all shiny parts. Be careful about using a pressurized rinser on the ball bearings. Always lubricate the machine after cleaning. Then leave the machine to run for a few minutes.

5.7 Lubrication

Press grease into the lub nipples at least once a week. Lubricate the main power transmission shaft every day. For the roller chains we recommend a special lubricant which lubricates all links without resulting in a sticky, dust-attracting surface.

See lub-chart on the machine and in fig. 63.

5.8 Maintenance of drive shafts

When replacing a web drive, be sure to mount a drive with the right spacing:

Web rod spacing 21mm 11 tines (2 x order no. 255629 + 2 x 255630)

Web rod spacing 25 and 30mm 10 tines (4 x order no. 255627)

When the support disc at the centre of the drive shaft for the first web (at the web turning wheel) has been strongly worn, we recommend to carry out repairs by welding on a plate segment. Otherwise the web may be damaged. Use 2 x order no. 257442; place them on one side of the original support disc and weld them on.

