

**Operator's manual**  
**2-row potato harvester**  
**UN2200**  
**inclusive options**

UH121510

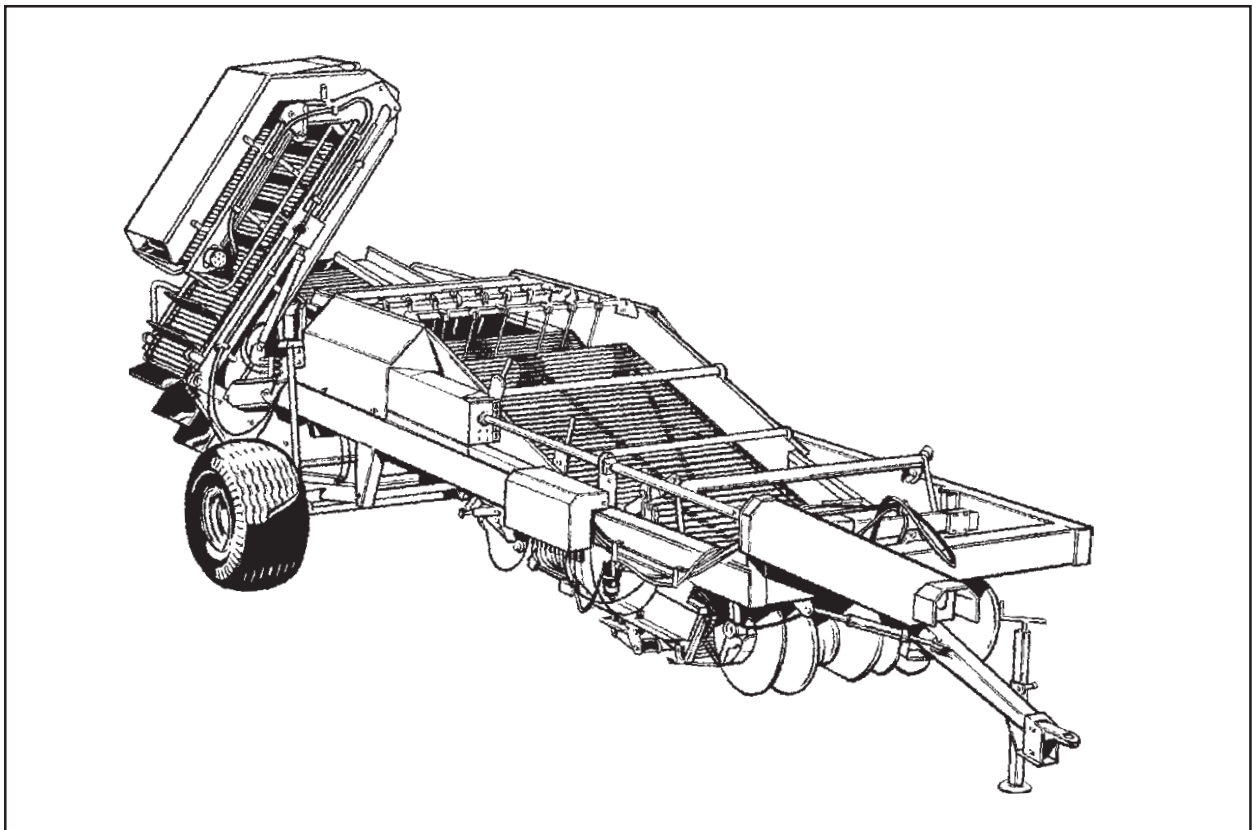



## CE certificate of conformity

We,  
**TKS Mekaniske AS,**  
**Torlandsvegen 3**  
**N-4365 Nærbø**  
**Norway**

declare under our sole responsibility that the product:

Potato harvester UN2200

to which this declaration relates corresponds to the relevant basic safety and health requirements of the Directives 89/392/EEC, 91/368/EEC, 93/44/EEC and 89/336/EEC.

Nærbø, 13 juni 2007



Henning Thunheim  
Managing Director

**Enter here the identification (serial)  
number of your machine:**

\_\_\_\_\_

TKS, manufacturers of farm machinery reserve the right to change designs and/or specifications without notice. This does not include an obligation to make changes to machines previously supplied.

# Guarantee

TKS product's are guaranteed for a period of one year from the date of delivery, against defects in material and workmanship.

Component's not manufactured by TKS, i.e. electrics and hydraulics, p.t.o. shafts and tyres are guaranteed according to the original manufacturer's recommendation.

The components listed below have limited guarantee due to their function.

Tyres

Shares

Webs

Web rollers

Axial rollers

Fuses

Safety clutches

PTO shafts

Hydraulic seals for pumps, motors, valves and cylinders - Oil filter

Weakening due to wear and tear is considered to be normal for these parts. The product guarantee for these components is limited to manufacturing defects, breakage, poor workmanship, transport damage etc on new machines.

If a failure is expected to be covered under the guarantee, the owner or its representative should inform the dealer when parts and/or repair work is required. Any guaranty claim should be applied for within the period of guarantee.

The dealer should fill in one guarantee claim form for each matter and forward it to the TKS sales company or importer before the 10th of the following month after the claim was raised.

The damaged parts should be marked with the number of the corresponding warranty claim and should be stored for 6 months by the dealer, available for inspection by the TKS sales company or importer if required.

Due to the operation of the TKS products being out of the manufacturer's control, the guarantee covers the product quality only. Performance or any consequential losses are not covered.

The guarantee may be invalid if:-

- a) spurious spare parts are used or the product is repaired or modified without the TKS authorization.
- b) operators and service instructions given by the manufacturer are not complied with.
- c) The machine is used for other purposes than those designed for.

The guarantee does not cover damage caused by normal wear.

Public safety regulations require from the manufacturer of this machine that all safety aspects regarding the use of the machine is thoroughly evaluated. As a result of these obligations TKS and its importer or sales company are not responsible for the function of components not shown in the spare parts catalogue covering this product.

TKS reserve the right to change the product with no obligation to previously supplied machines.

# Content

CE certificate of conformity .....	3	5.1 P.T.O. Speed Revolutions .....	31
Guarantee .....	4	5.2 Row adjustment .....	31
Content .....	5	5.3. Adjusting the lifting unit .....	31
Introduction .....	6	5.4. Share angle .....	31
Machine identification .....	7	5.5 Belt agitation .....	33
Dimensions .....	8	5.6 Clod crushing .....	33
Technical specifications .....	9	5.7 Haulm removal .....	33
Model description .....	11	5.7.1 Haulm rollers .....	33
Safety 13		5.7.2 Haulm elevator .....	33
General safety precautions .....	13	5.8 Cleaning web .....	33
Supplementary safety instructions for 2200 potato planters .....	17	5.9 Discharge elevator .....	34
Lifting machine with crane .....	17	5.10 Picking table .....	35
Hazard with the use of chemicals .....	17	5.11 Axial cleaning rollers .....	35
New machine - be careful! .....	19	5.11.1 Roller speed .....	35
1 PREPARING A NEW MACHINE .....	21	5.11.2 The angle of the roller unit .....	35
1.1 Wheels .....	21	5.11.3 Hydraulic working pressure .....	35
1.2 Drawbar .....	21	5.11.4 Auto reversing system .....	35
1.3 Elevator .....	21	5.11.5 Roller scrapers .....	35
1.4 Picking table .....	21	5.12 Alarm .....	35
1.5 Haulm elevator .....	21	5.13 Levelling .....	35
1.6 Elevator reversing hydraulic kit .....	21	5.14 Adjusting machine's height on wheels .....	35
1.7 Separate discharge elevator control .....	21	5.15 Picking table canopy .....	35
1.8 Clod crusher on main web .....	23	6 MAINTENANCE .....	36
1.9 Control panel .....	23	6.1. Wheel pressure .....	36
1.10 P.T.O. shaft .....	23	6.2 Belt tensioning .....	36
1.11 Falldamper chute for elevator end .....	23	6.3 Drive chain tensioning .....	36
1.12 Canopy for picking table .....	23	6.4. Lubrication .....	37
1.13 Main web cleaning roller .....	23	6.5. Oil filters .....	37
1.14 Hydraulic diabolo relief unit .....	23	6.6. Oil change .....	37
1.15 Miscellaneous options .....	23	6.7. Hydraulic valve bank .....	37
1.16 Final control .....	23	6.8. Axial rollers .....	37
2 TRACTOR REQUIREMENTS .....	25	6.8.1 Rollers .....	37
3 CONNECTING THE MACHINE TO TRACTOR .....	27	6.8.2 Resetting of the auto reversing system .....	37
3.1 Drawbar height .....	27	6.9. Cleaning .....	38
3.2 P.T.O. shaft .....	27	6.10. Main web drive .....	38
3.3 Electric connections .....	27	6.10.1 Web tension rollers at the lower drive roller .....	39
3.4 Hydraulics .....	27	6.10.2 Special rubber drive discs with teeth .....	39
4 ROW WIDTH ADJUSTMENT .....	29	6.10.3 Positive web drive using steel sprockets .....	39
5 OPERATING THE HARVESTER .....	31	7. TROUBLE SHOOTING .....	42
		Notes 44	

## Introduction

We congratulate on the purchase of your new TKS product. You have chosen a product which will give you satisfaction through a network of efficient dealers where function, finish, after sales service and spare parts are always at hand.

All TKS products are designed and tested in close co-operation with farmers and contractors to ensure optimal function and reliability.

Please read this manual before using your new machine.

We wish you all the best with your TKS product.

Yours faithfully  
**TKS Mekaniske AS**



**TKS Mekaniske AS,  
Torlandsveien 3  
N-4365 Nærbø  
Norway**

**e-post : [post@tksmek.no](mailto:post@tksmek.no)**

**Phone +47 51 43 63 00**

**Fax +47 51 43 48 62**

# Machine identification

The machine's serial number and the manufacturer's address is found on the number plate of the machine. See illustration below.

The serial number and year of delivery for this machine is given below. This number is important with regard to service and the correct supply of spare parts.

The machine is marked CE. This marking with appurtenant EU statement of agreement means that the machine complies with substantial health and security demands, and that it is accordance with the directives 89/392/ECC as amended by directive 91/368/ECC and 93/44/EEC.

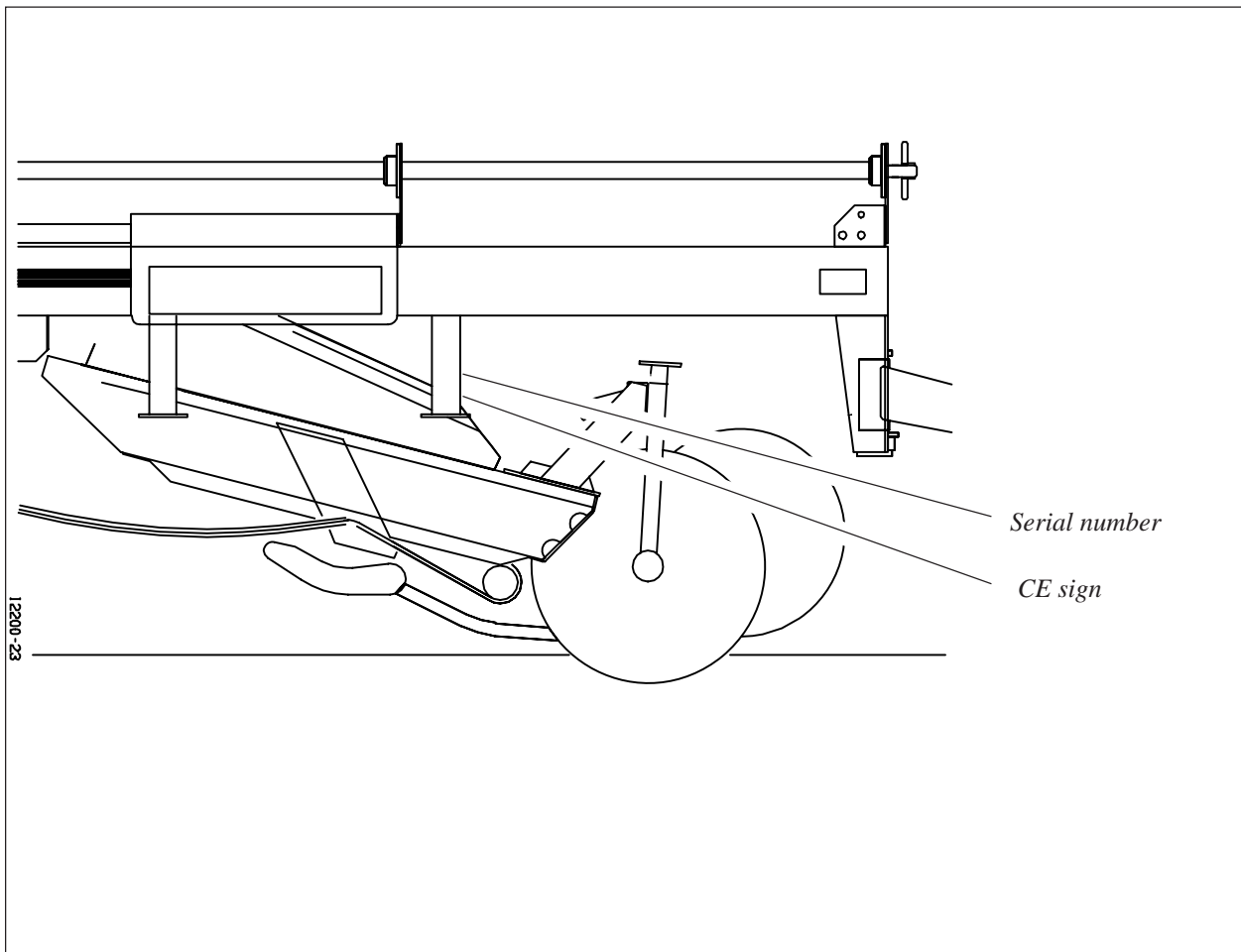

Serial number : \_\_\_\_\_

Year of delivery : \_\_\_\_\_

# Dimensions

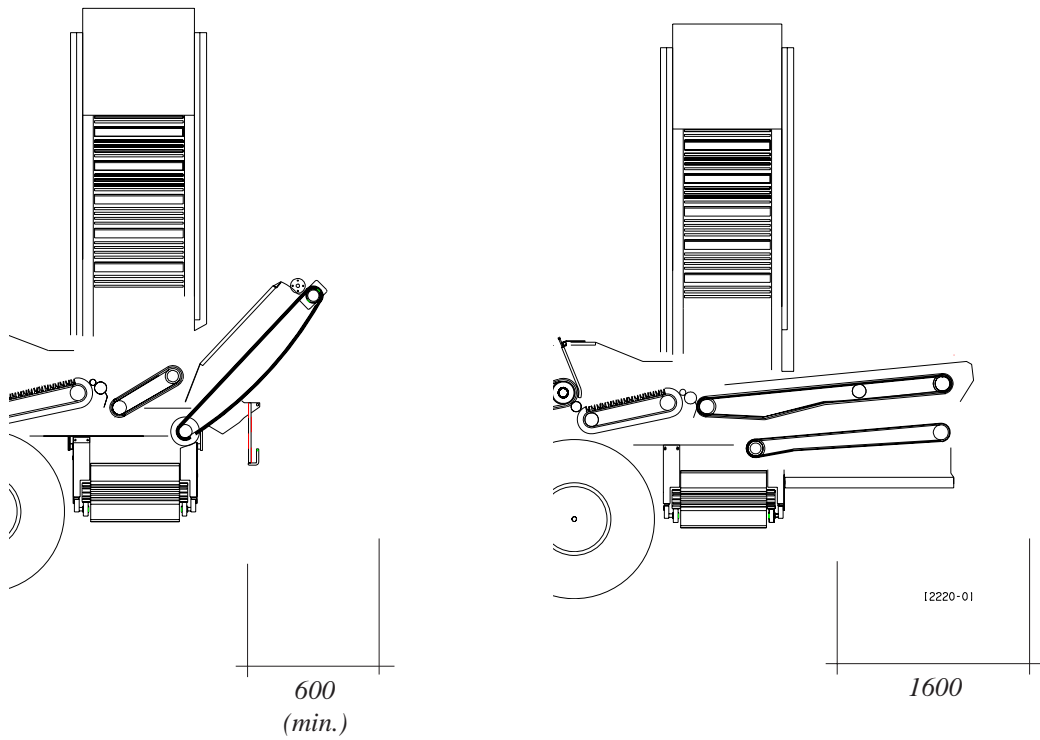
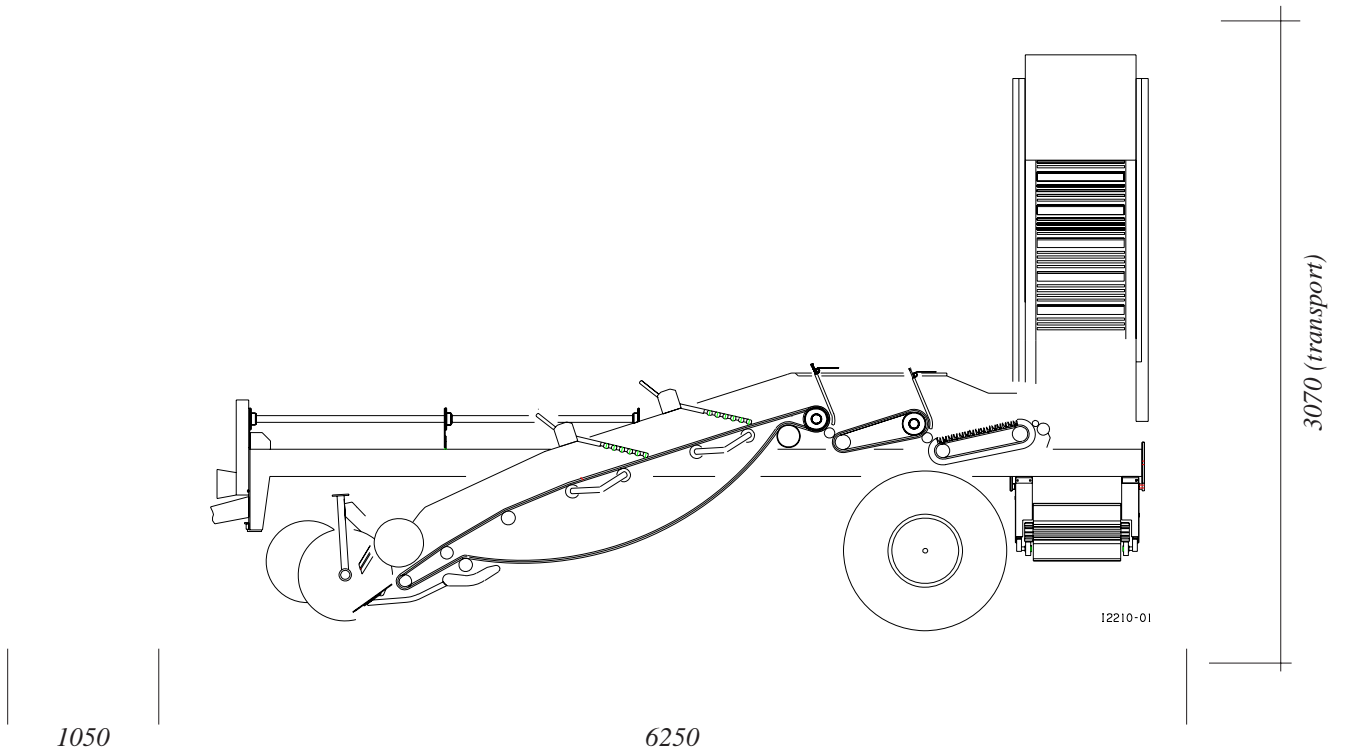

# Technical specifications

Covers machine with horizontal main frame and standard wheel dimension (500/50-17")

Harvester model:	2210	2212	2220	2222
<b>Tractor connections</b>	Hitch/ tractor drawbar 1 hydraulic outlet w/free return to tank	Hitch/ tractor drawbar 1 hydraulic outlet w/free return to tank	Hitch/ tractor drawbar 1 hydraulic outlet w/free return to tank	Hitch/ tractor drawbar 1 hydraulic outlet w/free return to tank
<b>Row width</b> (infinite)	70-90cm 28-36"	70-90cm 28-36"	70-90cm 28-36"	70-90cm 28-36"
<b>Shares</b>				
standard	3 blades	3 blades	3 blades	3 blades
extras	2 blades 1 blade full width	2 blades 1 blade full width	2 blades 1 blade full width	2 blades 1 blade full width
<b>Main web</b>				
width	1.50m	1.50m	1.50m	1.50m
web gap (standard)	29mm	29mm	29mm	29mm
web gap (option)	17, 25, 34, 39mm	17, 25, 34, 39mm	17, 25, 34, 39mm	17, 25, 34, 39mm
rod diameter	11mm	11mm	11mm	11mm
separation area	5.0m <sup>2</sup>	5.0m <sup>2</sup>	5.0m <sup>2</sup>	5.0m <sup>2</sup>
<b>Second web</b>				
width	1.50m	1.50m	1.50m	1.50m
web gap (standard)	29mm	29mm	29mm	29mm
web gap (option)	17, 25, 34, 39mm	17, 25, 34, 39mm	17, 25, 34, 39mm	17, 25, 34, 39mm
rod diameter	11mm	11mm	11mm	11mm
separation area	0.9m <sup>2</sup>	0.9m <sup>2</sup>	0.9m <sup>2</sup>	0.9m <sup>2</sup>
<b>Cleaning web</b>				
width	1.50m	1.50m	1.50m	1.50m
<b>Third web</b>				
width		1.50m		
web gap		24mm		
<b>Haulm elevator</b>				
width		1.50m		
area		2.1m <sup>2</sup>		
<b>Picking table</b>				
width			1.10m	1.10m
web gap			20mm	20mm
<b>Discharge elevator</b>				
loading height (standard)	3.05m	3.05m	3.05m	3.05m
loading height (option)	3.50m	3.50m	3.50m	3.50m
width (net)	0.63m	0.63m	0.63m	0.63m
<b>Axial rollers</b>				
length				0.95m
diameter spiral rollers				82mm
diameter smooth rollers				82 & 92mm
<b>Wheel dimensions</b>				
standard	500/50-17"	500/50-17"	500/50-17"	500/50-17"
option	400/55-22.5"	400/55-22.5"	400/55-22.5"	400/55-22.5"
	500/45-22.5"	500/45-22.5"	500/45-22.5"	500/45-22.5"
righthand side only	12.4/11-24"	12.4/11-24"	12.4/11-24"	12.4/11-24"
<b>Length inclusive drawbar</b>	7.30m	7.90m	8.90m	8.90m
<b>Transport width</b>	2.82m	2.82m	2.82m	2.82m
<b>Transport height</b>	3.07m	3.07m	3.07m	3.07m
<b>Total weight</b>	3350kg	3550kg	3650kg	4120kg
<b>Axle load</b>	2820kg	3050kg	3650kg	3720kg
<b>Drawbar load</b>	530kg	500kg	500kg	400kg

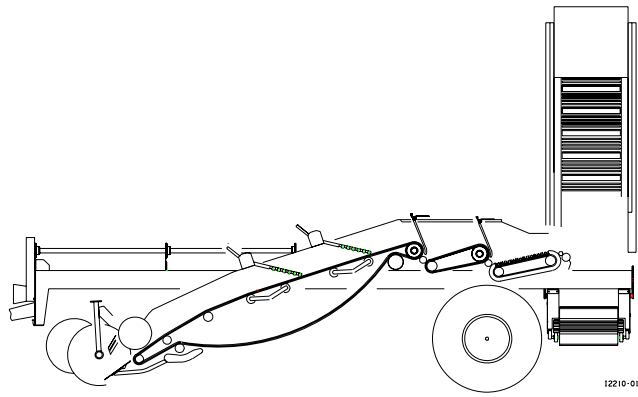

2210

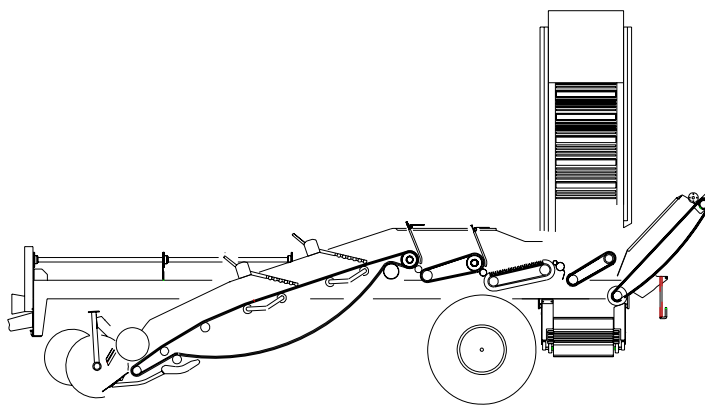

2212

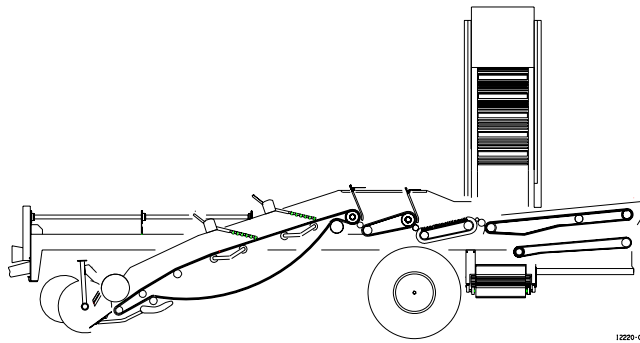

2220

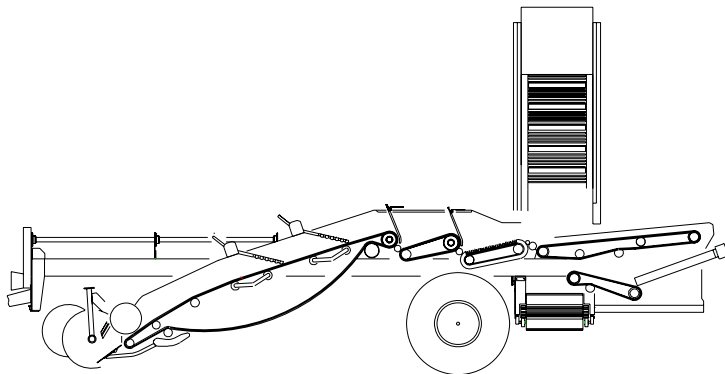

2222

# Model description

The 2200 potato harvester from TKS is a two-row elevator machine. The machine is supplied without a picking table and is then called model 2210. With a haulm elevator fitted the model is 2212. Supplied with a picking table the model name is 2220. With axial rollers integrated in the picking table the model is 2222.

The machine is supplied with an elevator and a loading height of 3 meters as standard. Elevator with a loading height of 3.5 meters may be supplied as an option.

The machine may be supplied with one or more options:

- Haulm guide shoes (prevent haulm from blocking at the edges of the lifting units)

- Roll-back plates at the outer roller discs (stop potatoes from rolling out of the machine at large distance between haulm pull-in rollers and roller disc)

- Centre haulm pull-in wheel (stop haulm building up between the centre roller discs)

- Optional shares are listed in Technical specification page 9.

- Full width share is included with combi windrowing kit, share for bed and Non stop harvesting kit.

- Half diabolos (used on beds together with bed lifting share, Non-stop and combi windrowing kits)

- Non-stop harvesting equipment by simply using the field as temporarily store the harvester keeps working even when an empty trailer arrives late)

- Windrowing equipment (windrow and lift the potatoes with the same machine)

- Hydraulic diablo relief unit (reduces the pressure on the depth adjustment rollers, to be used on soft soil)

- Hydraulic lane adjustment for drawbar (replaces turnbuckle, simplifies the lane adjustment, particularly on slopes)

- Drawbar extension (reduce tractor's turning circle when fitted with large wheels and/or large wheel distance)

- Optional web types are listed in Technical specification on page 9.

- Cleaning roller for main web (cleans soil off the belt rods, according to the various rod distances)

- Optional wheel sizes are listed in Technical specification on page 9.

- Elevator hopper chute (reduces free dropping height, forms a flexible end to the elevator)

- Canopy over operator table

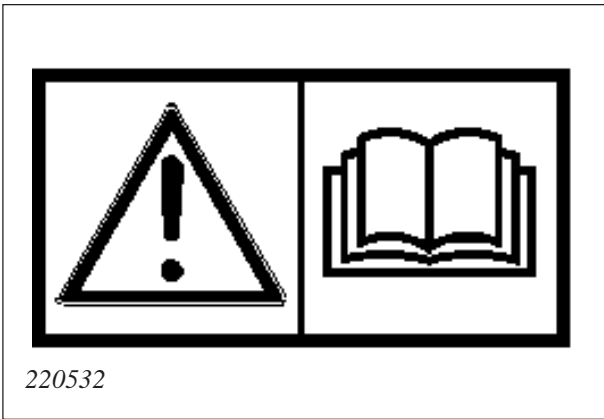

Fig. 1

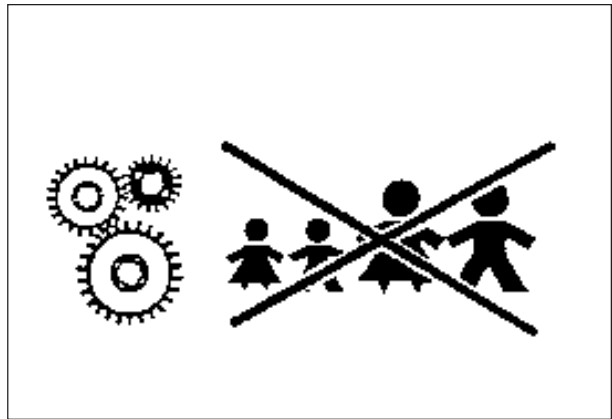

Fig. 2

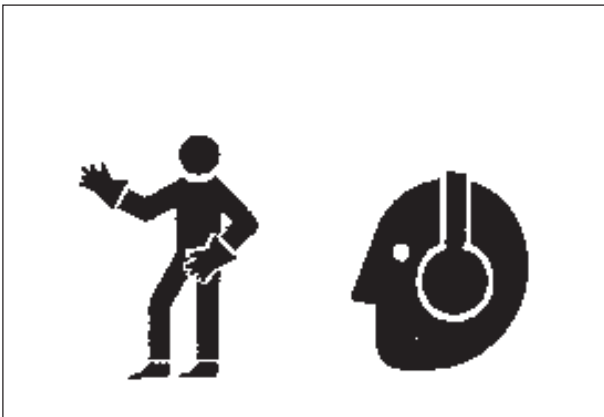

Fig. 3

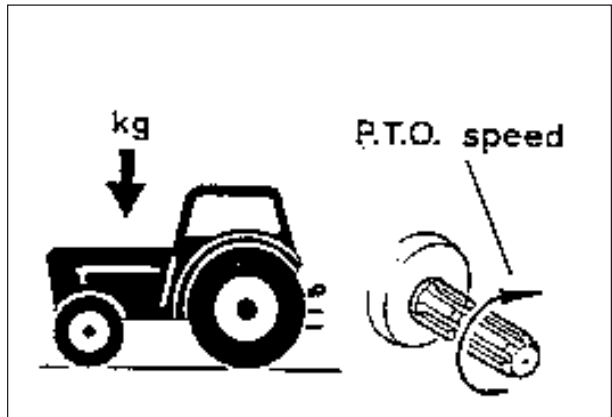

Fig. 4

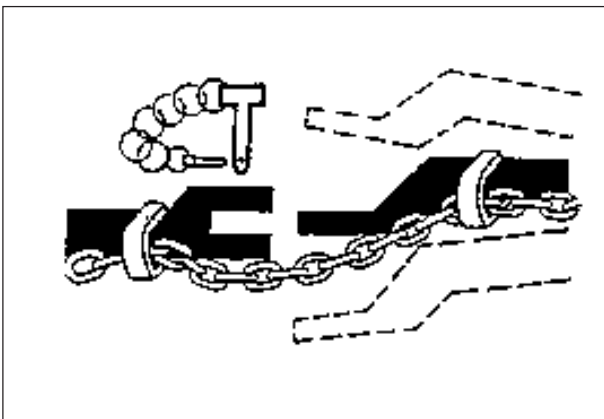

Fig. 5

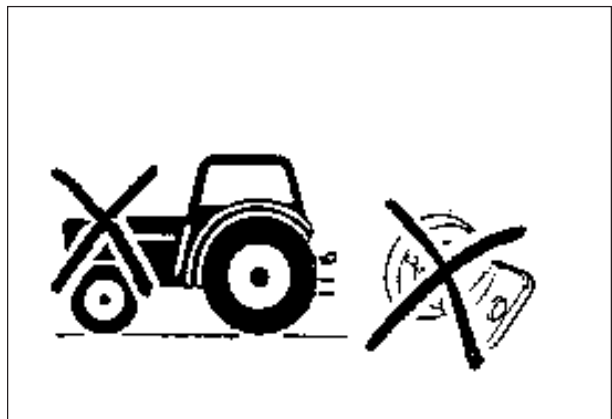

Fig. 6

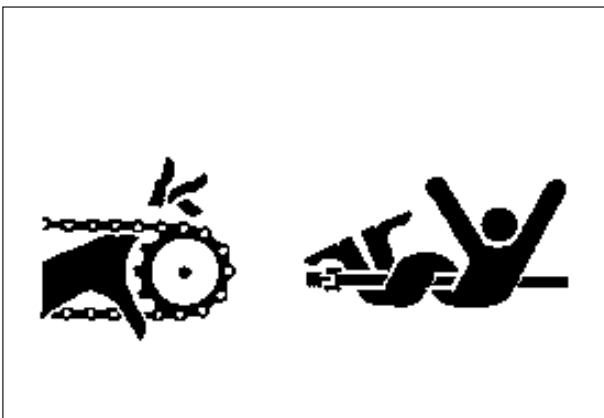

Fig. 7



Fig. 8

# Safety

Before operating, adjusting or servicing the machine it is important that the safety instructions in this manual are carefully read and understood by those directly concerned (Fig. 1).

Whilst all care and attention has been taken in the design and production of this machine, as with all machinery there remains a certain amount of risk to personnel whilst the machine is in use. It is strongly recommended that users and operators take all possible precautions to ensure both their own safety and that of the others that may be in the vicinity. Read and observe the safety instructions in this manual. Safety is your responsibility!



Pay particular attention to this symbol. It means that there could be a serious hazard. It emphasises precautions which have to be complied with in order to prevent accidents.

This symbol can be found throughout this manual and on the warning signs of the machine. They are for your safety and should be observed at all time.

## General safety precautions

### **Be careful when other people or animals are close by!**

Never start the machine when people or animals are close by tractor or machine. Never stand between the tractor wheels and the machine. (Fig. 2)

Bear in mind regulations regarding the lower age of operators of this kind of machines.

### **Use of the machine**

The machine should be used only for the purpose it has been designed for.

### **Use personal protection devices**

Do not wear loose clothing which might catch in any of the moving parts. In dusty conditions an approved mask must be used. (Fig. 3)

Take care of excessive noise level. Some tractor/ implement combinations, depending on conditions, may cause noise level beyond 85dB at the operator's ears, even in a 'Q' cab. In these conditions ear defenders must be worn. Keep cab windows and doors closed to reduce noise level.

### **The machine must be connected to a correctly sized tractor**

The weight of the tractor must correspond to the maximum weight of the machine when operated. Follow domestic law and regulations. (Fig. 4)

Make sure that the tractor has the correct P.T.O. gear engaged. A machine designed for an input speed of 540 r.p.m. should never be connected to a tractor with 1000 r.p.m. output speed engaged. The normal P.T.O. speed is given on a label close to the

P.T.O. input shaft.

### **Connecting machine to tractor**

must always be carried out as described in this manual. If connection should be carried out with drawbar, one of the parts (tractor's or machine's drawbar) must have a clevis. The drawbar pin must be secured with a lock pin. (Fig. 5)

Observe national regulations regarding road transport. Some countries require the use of safety chain when a trailed machine is towed along public roads.

### **Think of safety while operating the machine**

Stop the tractor engine and remove the ignition key prior to carrying out repairs, cleaning, lubrication or maintaining the machine. (Fig. 6)

### **Safety guards**

Make sure all guards are in good order and fitted correctly. Do not attempt to start the machine before ensuring this. (Fig. 7)

Pay particular attention to the plastic guards of the P.T.O. shaft. If damaged they must be replaced. The chain locks of the guards must always be fitted on a suitable place on the tractor and the machine to prevent the outer plastic guards turning.

### **Hydraulics**

Be very careful when dealing with hydraulics. Use eye protection and gloves. Escaping hydraulic oil under pressure might penetrate into the skin and cause serious infection. See a doctor if you have been exposed to injury. (Fig. 8)



Fig. 9

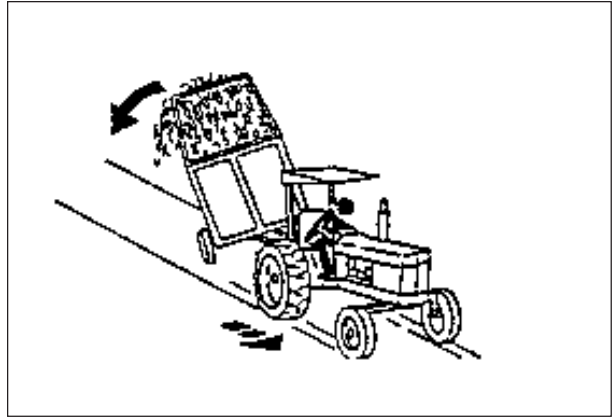

Fig. 10

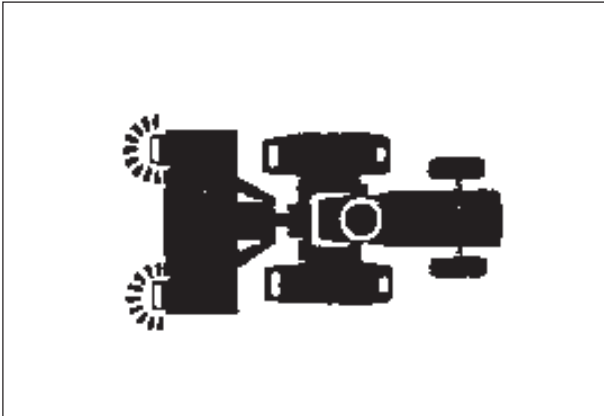

Fig. 11

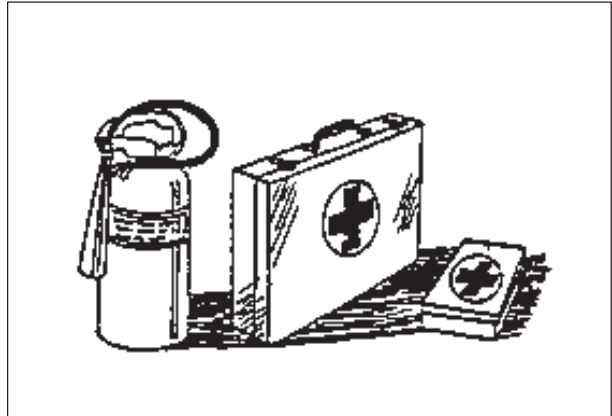

Fig. 12

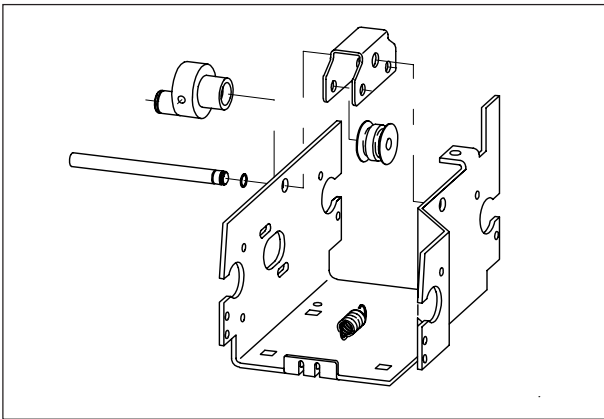

Fig. 13

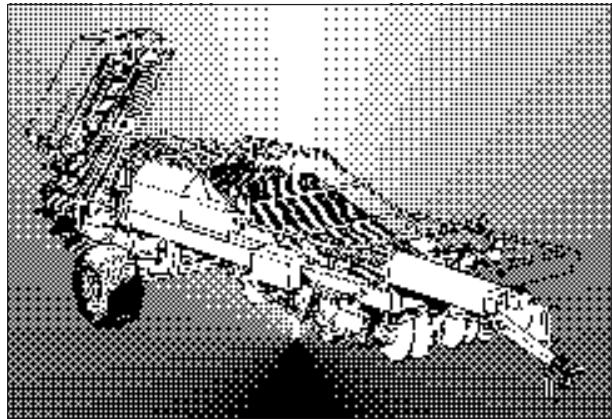

Fig. 14

Take care that nobody is close to the machine when the hydraulic functions are being operated.

**When uncoupling machine and when leaving tractor/machine**

When uncoupling, all hydraulic functions must be in neutral position. The machine must be lowered to the ground and be safely secured. If the machine have parking chocks they should be used at the wheels. Never allow children to play or stay near agricultural machinery. (Fig. 9)

**Drive safely**

Beware of your responsibility, - carelessness or negligence may cause serious injury or even death. (Fig. 10)

Prior to transporting the machine along public roads, check wheel bolts and couplings. Disconnect or lock the hydraulic system.

Drive carefully. Reduce speed when turning and driving on uneven ground. Take care that trailed machine does not start swinging or become unstable.

Please be aware of the danger of overturning when working on slopes and in soft ground. Reduce load.

**Lights**

The owner and operator is responsible of providing correct lamps and reflectors on the machine when transported on public roads. Comply with public regulations. (Fig. 11)

**Safety equipment**

Always carry first aid equipment on the tractor. Also observe the regulations concerning fire extinguisher. When working with burning materials like hay and straw a fire extinguisher must be available at all times. (Fig. 12)

**Spare parts**

For safety reasons use only original spare parts. The use of spurious spare parts will cause the TKS product guarantee to be invalid. (Fig. 13)

**Maintenance**

Take care that the machine is properly maintained

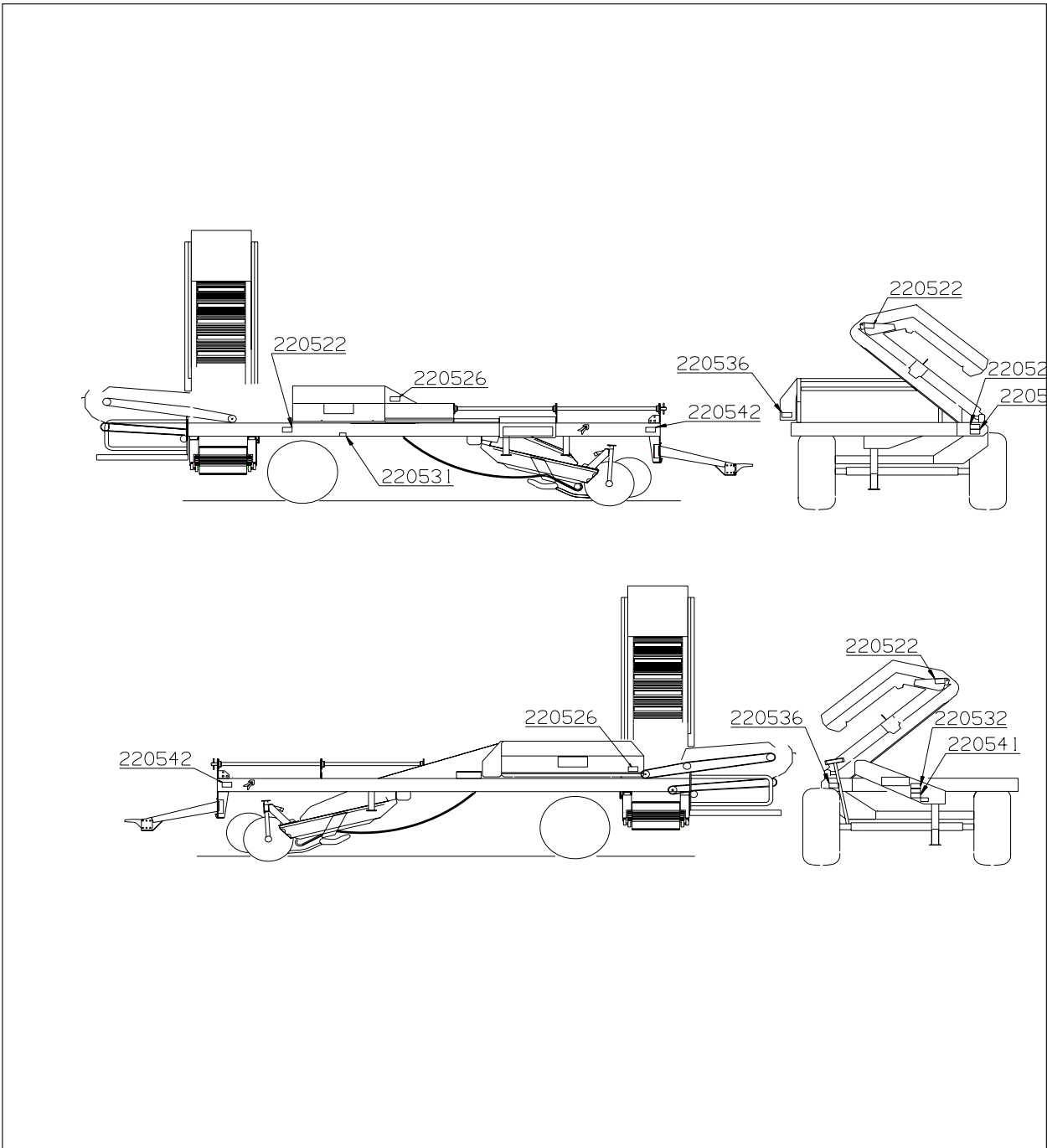

Fig. 15

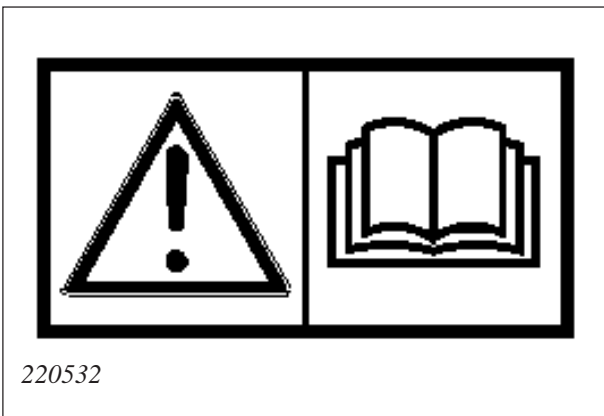

Fig. 16

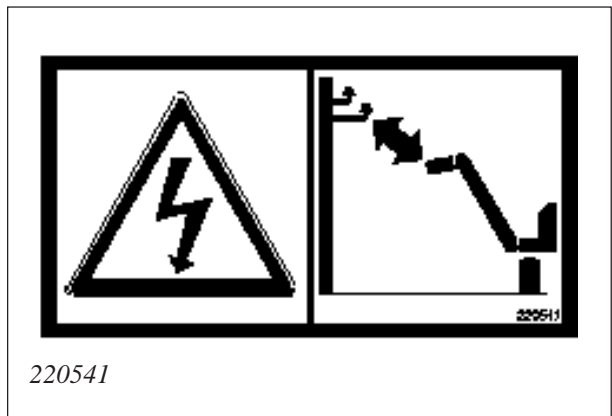



Fig. 17

# Supplementary safety instructions for 2200 potato planters

This machine is designed for the purpose of harvesting potatoes and similar tubers. It has been designed to be operated unmanned if not equipped with a specially built picking table with platforms for the operator(s).

The machine is equipped with  warning signs. If any of the decals are damaged, they must be replaced. Ordering numbers are shown on the illustrations in this paragraph. Fig. 15

**Warning sign 220532 (fig. 16).** Be careful! Read and understand the instructions in this manual before the machine is put into service and before attempting adjustment/maintenance.

**Warning 220541 (fig. 17).** Be careful when passing close to overhead powerlines. The height of the machine may exceed 5 meters when the elevator is fully raised to vertical position.

**Warning sign 220536 (Fig. 18).** Squeeze risk. Keep distance from moving parts.

**Warning sign 220522 (Fig. 19).** Squeeze risk. Keep distance from elevator. It can move without notice.

**Warning sign 220542 (Fig. 20).** Be careful when machine is lowered! Keep feet away from shares and wheels.

**Warning sign 220526 (Fig. 21).** Fingers could be cut off if caught by the roller chain.

**Warning sign 220531 (Fig. 22).** Lock the track markers prior to transport or parking with raised markers.

**Warning sign 220543 (Fig. 23).** Squeeze risk. Keep distance from rotating axial rollers.

**Warning sign 220540 (Fig. 24).** Squeeze risk. Keep distance from rotating haulm rollers.

## Lifting machine with crane

Only use approved lifting device. An approved lifting strap made specially for this machine is supplied with the machine. The weight of the machine is given in «Technical specifications» on page 5.

Be careful! Make sure that nobody stands under or near the machine when it is being lifted.

Attach lifting strap in brackets on lefthand and righthand side of main frame close to the lifting unit and at the forward side of the elevator on the righthand side of the machine. Look for the lifting hook signs. Make sure that straps are securely fastened before lifting.

Use a guide wire to keep machine in position.

## Hazard with the use of chemicals



Always follow the manufacturer's safety precautions regarding the handling of chemicals and fertilizers.

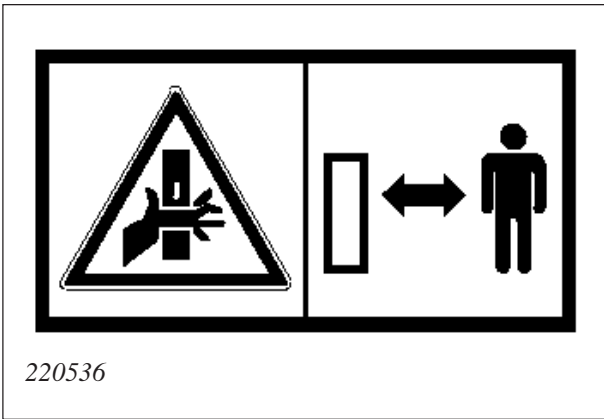

Fig. 18

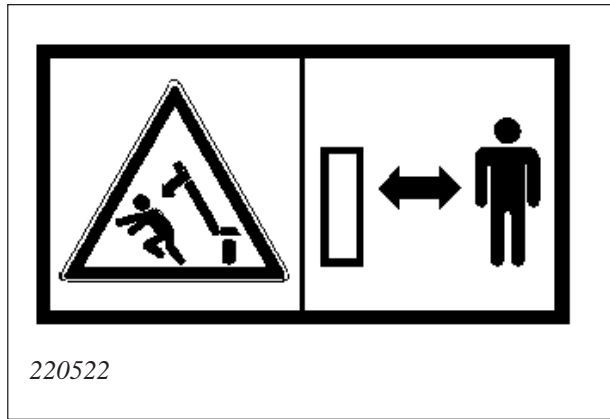

Fig. 19

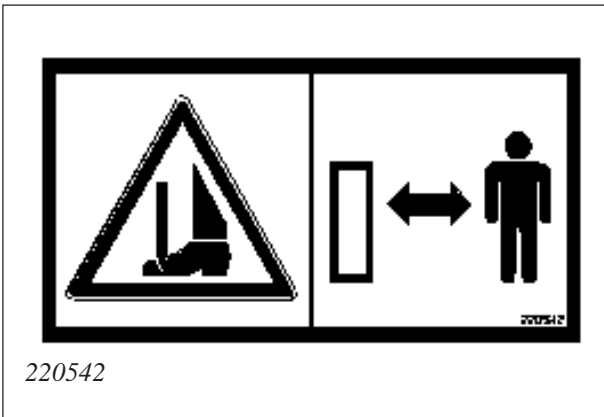

Fig. 20

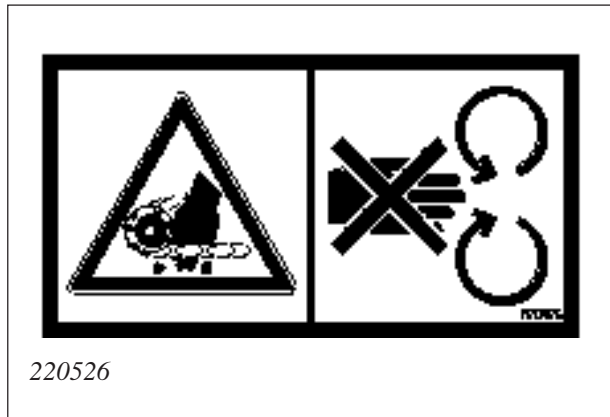

Fig. 21

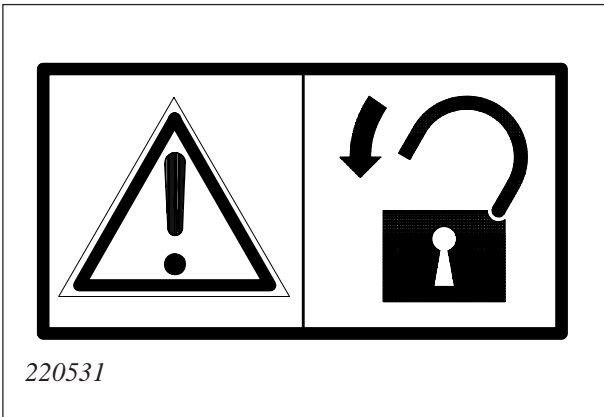

Fig. 22

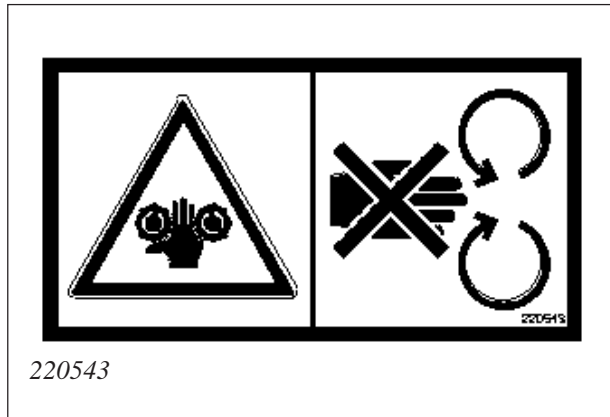

Fig. 23

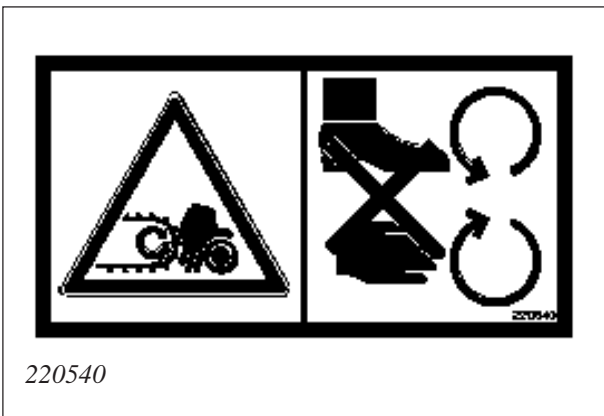

Fig. 24a

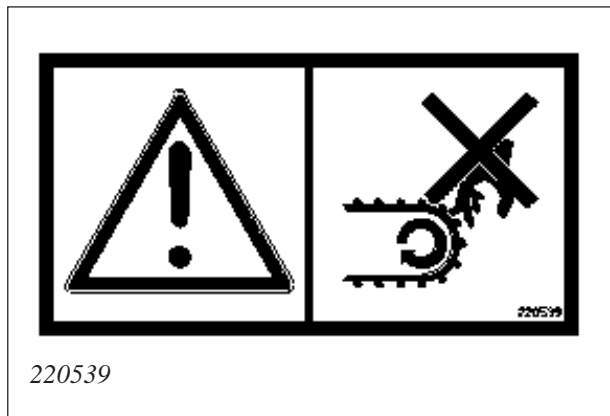

Fig. 24b

## New machine - be careful!

Read the operator's manual. Great care must be taken when starting a brand new machine for the first time. Incorrect assembly, faulty operations etc. may cause expensive repairs and loss of profit. The TKS product guarantee does not cover damage occurring when the instructions given in this book are not followed.



Pay particular attention to this symbol, - it emphasises operations where great care must be taken in order to avoid incorrect assembly, faulty operations etc.

Make following checks when starting a new machine:

Check that the machine is mounted correctly and that it is not damaged. Assure that electric wirings and hydraulic hoses have length and position that allow machine to move without causing any damage to the them.

Check the connections between tractor and machine.

Check that drive chains are in position on sprockets and properly tensioned.

Lubricate the machine according to paragraph «5.7. Lubrication».

Check wheel and drawbar bolts, the connections between main frame and picking table between elevator and main frame.

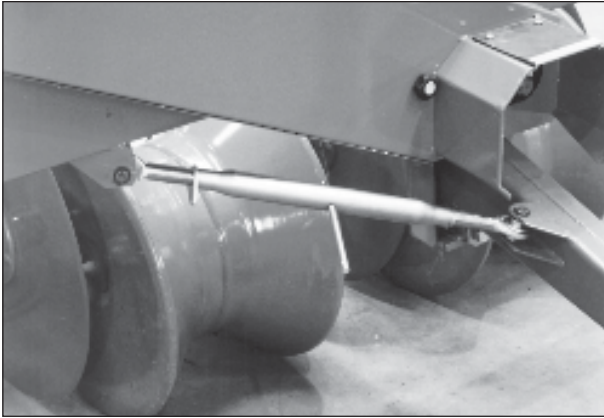

Fig. 25a

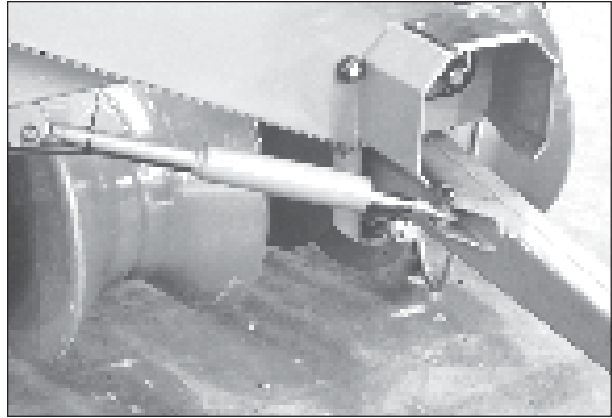

Fig. 25b



Fig. 26

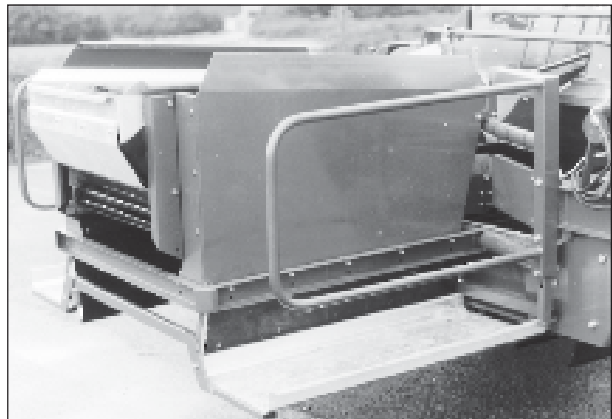

Fig. 27

# 1 PREPARING A NEW MACHINE

## 1.1 Wheels



Fit any wheels (removed for transportation) when machine is lifted off lorry. Any wheel rims must be fitted opposite to the tractor's wheel rims. **Fasten the wheel nuts properly (conic surfac on nut to face the rim).**

## 1.2 Drawbar

Fit the drawbar and the turnbuckle (or drawbar cylinder) (Fig. 25). Grease drawbar pin whilst still unconnected.

## 1.3 Elevator



If discharge elevator for transport reasons is not fitted, it should be connected to the main frame (four points). Connect the hydraulic hoses (join hoses marked green, and join hose marked blue with hose marked red if machine has no picking table or haulm elevator). See paragraph 1.4. or 1.5. as hydraulic connections of picking table and haulm elevator regards. See also Fig. I at the back of this manual.

Fit the canvas across the end of the elevator (Fig. 26). If combi windrowing kit is fitted the canvas should cover the centre section. **Observe! If machine should be transported over long distance at high speed prior to delivery to customer, the canvas should be fitted at arrival on the farm.**

## 1.4 Picking table

(Model 2220 & 2222 only)



Fit the picking table if this has been dismantled due to transportation requirements (Fig. 27). Tension the frame bolts thoroughly. Connect the hydraulic hoses of the picking table drive to the elevator return hose (join hoses marked red, and join hoses marked blue). See even Fig. II at the back of this manual.

(Model 2222 only)

Connect axial rollers' hydraulic hoses as shown on Fig. VI at the back of this manual. Run the machine when machine is ready (see paragraph 1.16. Final check of machine).

## 1.5 Haulm elevator

(Model 2212 only)

Fit haulm elevator if not done at the factory. Connect it to rear end of main frame beams. Connect hydraulics to the discharge elevator's return hose (join hoses marked red, connect hose marked blue to the T-joint of the Ex port of the speed control). See Fig. III at the back of this manual.

## 1.6 Elevator reversing hydraulic kit

(Option for models 2212, 2220 and 2222, factory fitted ordering no. 96111, separate kit ordering no. 2288)

The kit is used to maintain normal working direction of picking table and haulm elevator when the discharge elevator is reversed (done when Non stop kit is used). The kit consist of four non return valves connected in a way that oil flow to the picking table/haulm elevator is rectified independant of the entry.

Fit the kit between discharge elevator motor/spool valve and the picking table's/haulm elevator's speed control. See Fig. IV at the back of this manual.

## 1.7 Separate discharge elevator control

(Option for models 2220 and 2222, factory fitted ordering no. 96110, separate kit ordering no. 2289)

The kit is used when operator wish to sop the discharge elevator while picking table keep moving. The kit is a solenoid operated by-pass valve fitted to the elevator hydraulics and controlled from tractor cab.

See Fig. V at the back of this manual. The pressure hose of the elevator is removed from upper port of rear valve bank section being replaced by the short one from the by-pass valve. The elevator pressure hose is then connected to the upper port of the by-pass valve as shown on Fig. V. The hose from the centre port of the by-pass valve should be connected via a T-piece to the return flow hose of the elevator motor (marked red).

The wiring from valve should be connected to the control panel of the machine. Drill a 18mm hole in the box for the wire nipple and a 16mm hole in the panel cover for the fitting of the switch. Fit switch and connect wirings as shown on Fig. V.

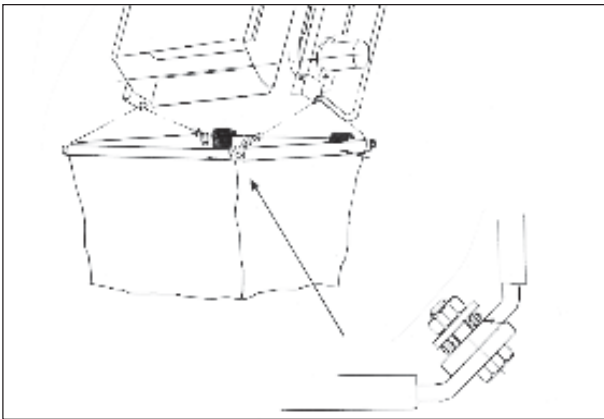

Fig. 28

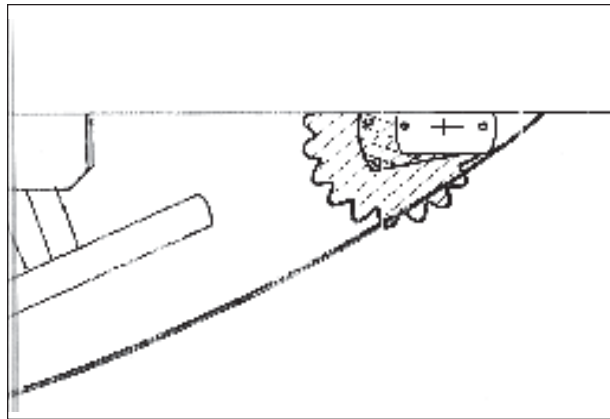

Fig. 29

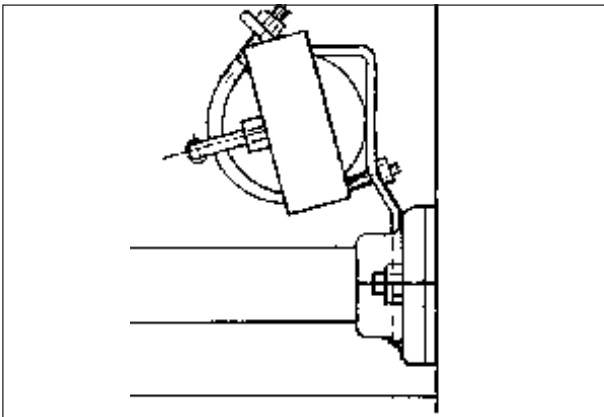

Fig. 30

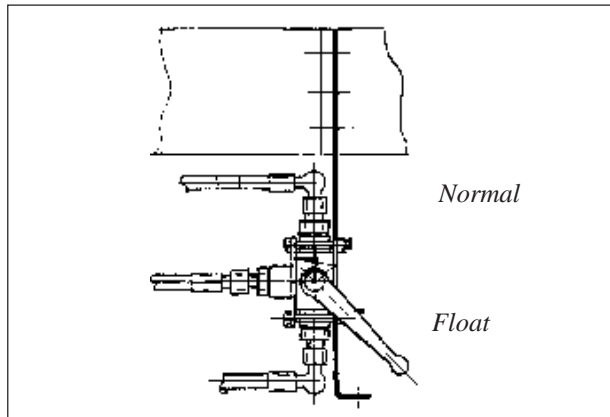

Fig. 31

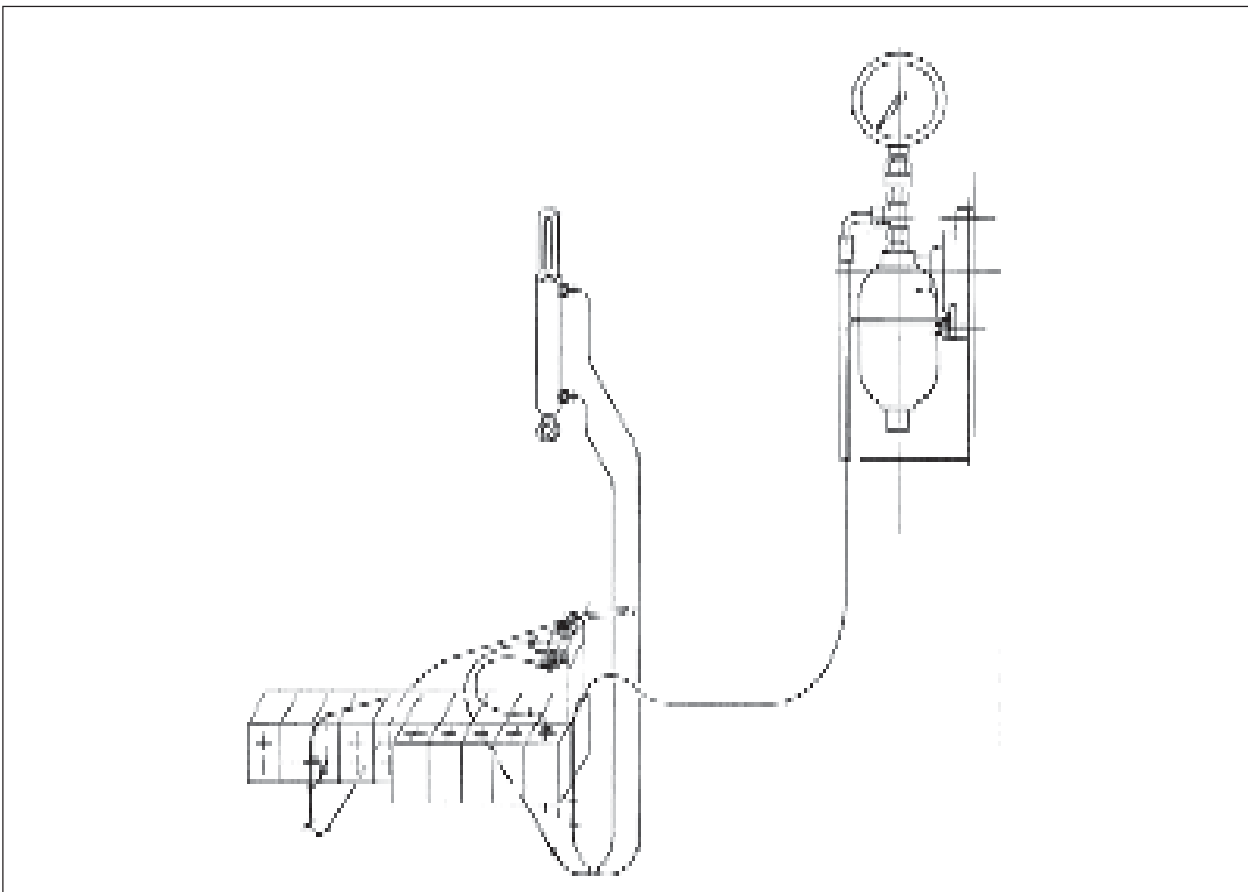

Fig. 32

## 1.8 Clod crusher on main web

If forward clod crusher is not fitted due to packing of picking table, it should be fitted with lever on the righthand side of the machine, like the rear one.

## 1.9 Control panel



Connect the control panel to the socket next to the machine's hydraulic services. In the tractor cab there should be a power connection (cigarette lighter socket or 12 volt socket) with a good battery connection. Solenoid should have minimum 10.8V. The simultaneous use of two solenoid require extra capacity on battery connection.

## 1.10 P.T.O. shaft



Check that length of P.T.O. shaft suits the tractor. Follow the instructions given on the shaft. There is a safety clutch fitted in the main drive line of the machine. Therefore the P.T.O. shaft should not have safety clutch included.

## 1.11 Falldamper chute for elevator end

(Option)

See fig. 28. When assembled the two rubber flaps should be attached over one of the long sides of the falldamper framework. When fitting the chute on the elevator end these rubber plates should be towards the elevator and work as shock absorbers for the chute frame.

## 1.12 Canopy for picking table

See separate fitting instructions.

Before the elevator is raised, the horizontal support bar at the front of the canopy must be laid down.

## 1.13 Main web cleaning roller

Is places inside the belt, attached to the frame bars (Fig. 29).

By changing to a belt with a different pitch, a new roller with same pitch must be fitted.

## 1.14 Hydraulic diabolio relief unit

Fit accumulator at front end of long drive shaft (Fig. 30) with scale against tractor driver.

Fit hoses according to drawing on Fig. 32. Connect accumulator hose with T-junction to front spool valve's lower port. Fit hose connected to upper port to directional valves's centre port. Connect the short hose from directional valve to spool valve's upper port and the long hose to main return hose using the T-junction. Attach directional valve to spool valve end guard (fig. 31).

Set lever to «Float» position. Lower the share. When reached working level **lift till gauge shows 40-50** (bar).

When set to «Normal» position the share lifting cylinder is acting as if floatation unit is not fitted.

## 1.15 Miscellaneous options

See separate fitting instructions.

## 1.16 Final control



Remove lifting straps and any other safety measures fitted for transportation. Check that no machine part can block belts etc. when the machine is started.

Check wheel bolts and drawbar connections.

**For machine with integrated oil pump:**



Check the oil level of the tank (level glass on the tank). Correct level at horizontal machine is upper half of level glass. Hydraulic oil HD46 is filled at the factory. Let the pump run for some minutes at PTO speed of approx 500 revs/min.

**For model 2222:**

When the auto reversing system is connected to the 12V power supply, the system should be tested. Control the function by pressing the button on the electronic control box. The rollers will reverse for a very short period (0.1 sec). When the button is released, the rollers will return to normal rotation. Refer to the separate operator's instructions covering the axial rollers. Check all mechanic and hydraulic functions



## 2 TRACTOR REQUIREMENTS

### Engine power:

Model	Easy conditions	Heavy conditions
2210 & 2212	65hp (48kW)	85hp (63kW)
2220	70hp (52kW)	90hp (66kW)
2222	75hp (55kW)	100hp (73kW)

### Hydraulic capacity:

Minimum 25 litres/min at 175 bar (tractor running at required engine speed).

### Connections:

Hydraulic hitch or drawbar

1 single acting hydraulic outlet with non resistance oil tank connection or 1 double acting outlet.  
The back pressure should not exceed 10 bar.

1 power connection 12V (cigarette lighter socket or 12 volt socket) for control panel

1 power connection 12V (battery cable included with machine) for axial rollers (model 2222 only)

### P.T.O. shaft

1<sup>3</sup>/<sub>8</sub>" 6 splines

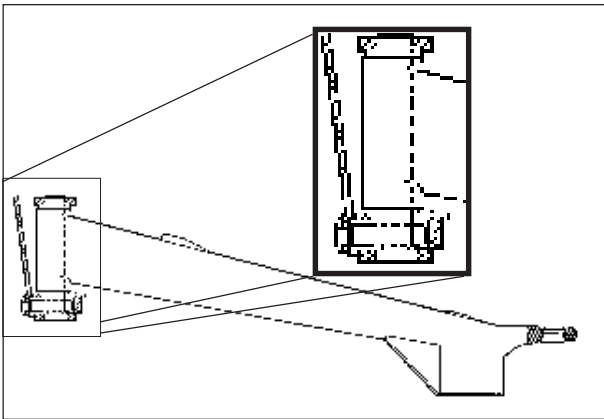

Fig. 33

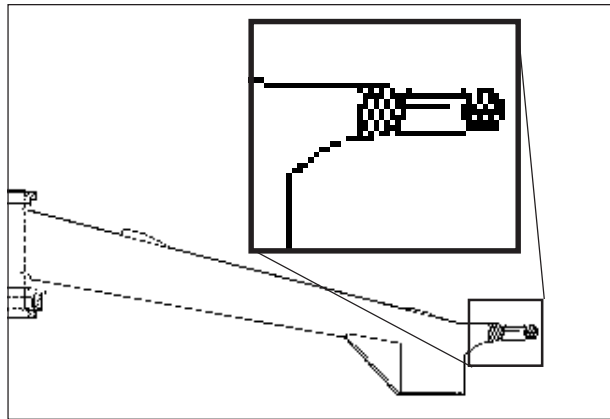

Fig. 34

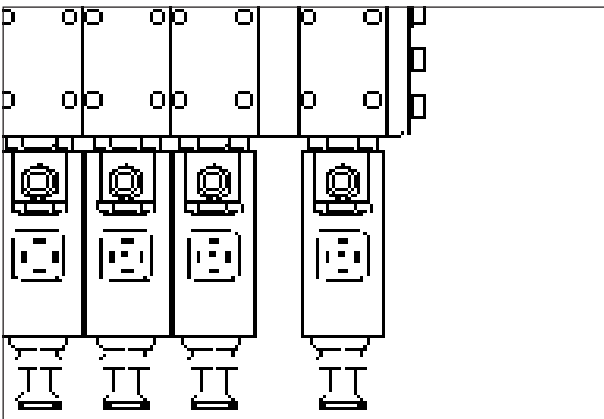

Fig. 35

## 3 CONNECTING THE MACHINE TO TRACTOR

### 3.1 Drawbar height

Adjust drawbar height for main frame to be parallel with the ground. Let the machine rest on the support foot and adjust the drawbar using the bolt behind the pivot point on the drawbar (Fig. 33). **Remember to refit the bolt security plate.**

The machine is connected to the tractor drawbar (fit drawbar in ring) (Fig. 34) or to the pickup hitch.

### 3.2 P.T.O. shaft

When starting a new machine the length of the P.T.O. shaft must be adjusted to allow it to slide freely yet have adequate overlap. This must also be checked when connecting to another tractor. Fasten the safety chains and check that the axle can move freely in both directions. See the shaft manufacturer's own information which is attached to all new shafts. Study the shaft manufacturer's instructions.

### 3.3 Electric connections

Connect the electric wires from the control panel to the tractor's cigarette lighter socket. If other connection has to be used the wire marked «I» must be connected to the +. Direct connection to the battery is possible, as there is a fuse in the control panel. Correct polarity is checked by testing the alarm system. If this remains silent, the plug wires must be switched. (The magnets will always work if only the voltage is high enough).

#### **Model 2222 only:**

The auto reversing system of the axial rollers requires a constant 12V power supply. The battery cable provided gives a good supply. The fused wire should be connected to the +12V terminal. If the safety valve system is not powered, there is a high risk of severe damage on the roller unit.

### 3.4 Hydraulics

The harvesters hydraulic hoses are identified as follows :

Flow: Yellow dust cap

Return: Blue dust cap, (a non return valve is fitted in the return line).

Avoid return connection which gives a high back pressure (above 5-10 bar).



The flow hose can be connected to a single acting spool valve and a return hose with free return to oil tank. Missing return will damage the machine's hydraulic valves and oil motor. If the levelling cylinder moves up with no use of the controls, there is no return to the tractor.



**When the machine is connected to a John Deere tractor (or other tractors with closed centre hydraulics), the harvester's spool valve centre must be closed. (The pin screwed into its stop, accessible from underneath the block, Fig. 35). When using other types of tractors this screw must be screwed fully out the head level with the central block edge.**

When working in dusty conditions, the top of the valve bank should be covered by some kind of filter material (rubber sponge) in order to prevent dust from intruding the valves through the caps on top of the spool guides.

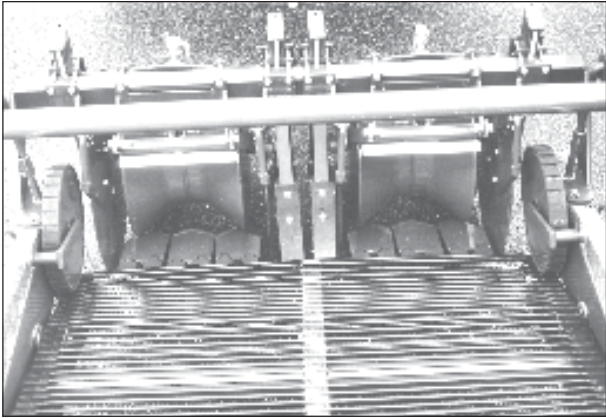

Fig. 36



Fig. 37

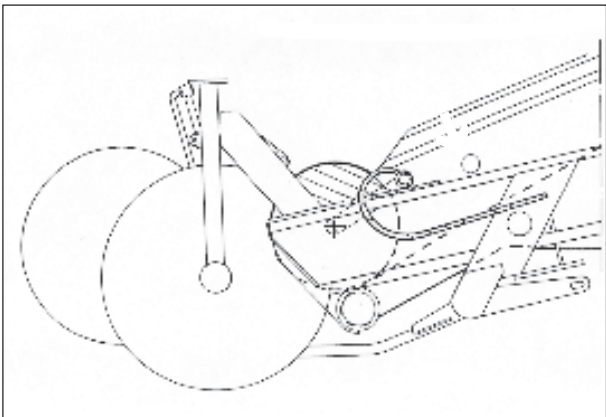

Fig. 38

## 4 ROW WIDTH ADJUSTMENT

Adjust the distance between the lifting units according to the row distance in the field. Standard distance when delivered from the factory is 750 mm. Both share, roller discs and diabolo rollers must be moved altering the row distance (Fig. 36).

When there is a large distance between the inner discs wide roll-back plates must be fitted (Fig. 37).

The lifting unit discs are mounted with a distance of 560 mm. The distance can be adjusted steplessly.

With wide row distance it might be necessary to remove or to move the haulm pull in rollers to the back position so as not to get in contact with the roller discs

(Fig. 38). The first belt roller should be moved in order to support the web at the haulm pull-in roller. Note that this is a less effective position as regards pulling in haulm.

At narrow row widths and small distance between the roller discs there is a risk of loss of potatoes between the disc and the pull-in roller. This may be stopped by fitting extra roll-back plates at the outer discs (option).

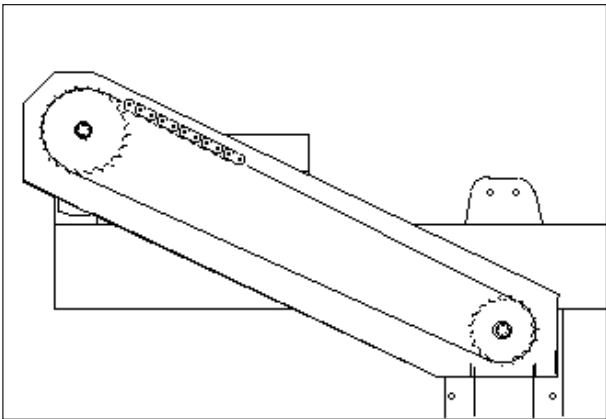

Fig. 39

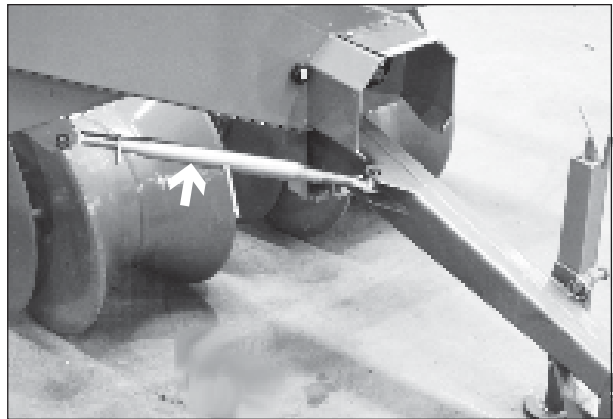

Fig. 40

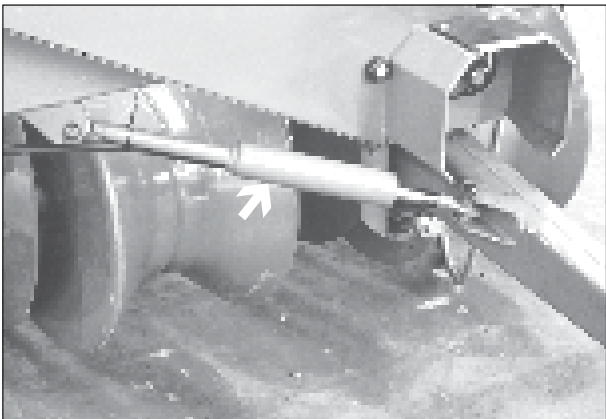

Fig. 41

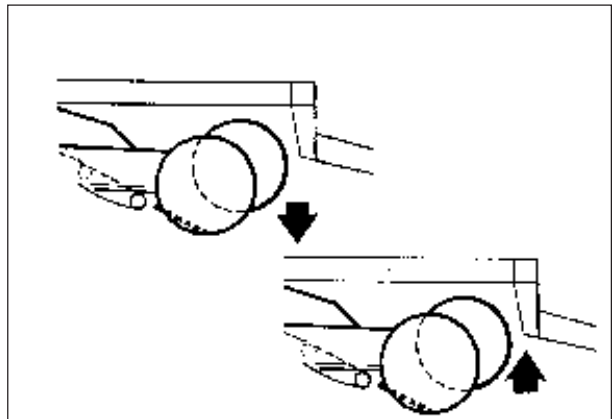

Fig. 42

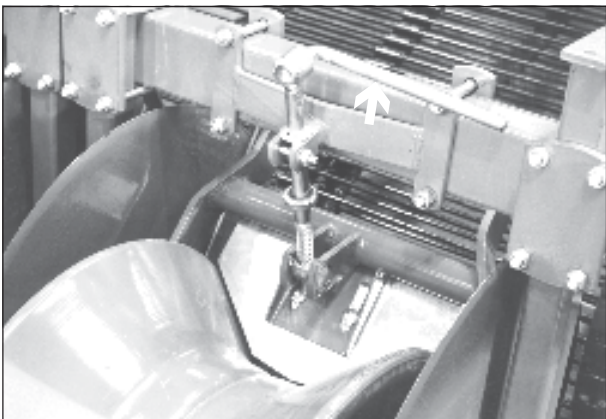

Fig. 43

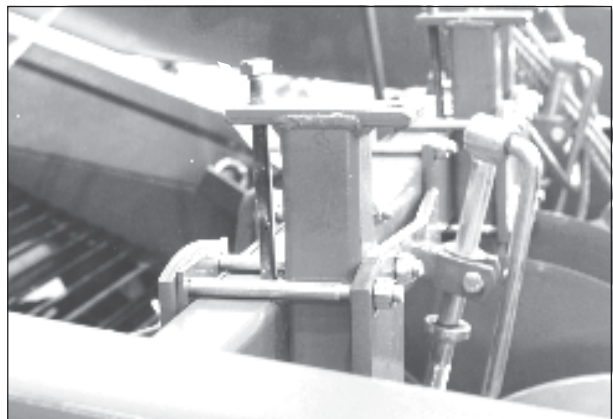

Fig. 44

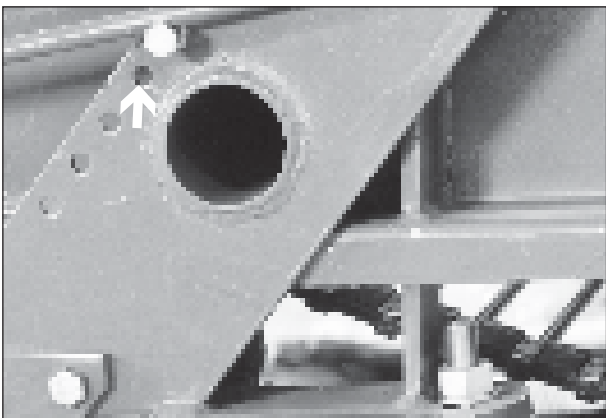

Fig. 45

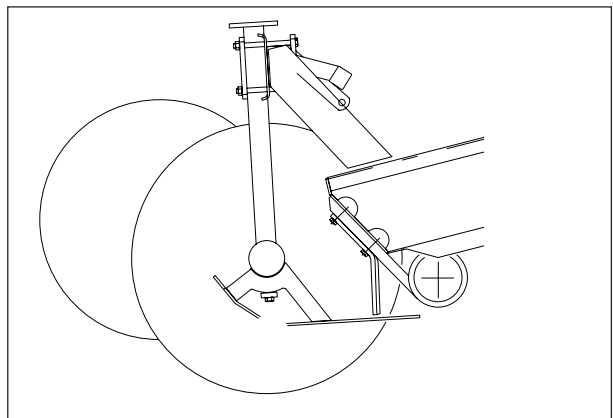

Fig. 46

# 5 OPERATING THE HARVESTER

## 5.1 P.T.O. Speed Revolutions

The recommended P.T.O. is 300-500 rev./min. An optional 16 or 14 teeth sprocket on the main drive shaft (Fig. 39) can be supplied instead of the 19 teeth standard one. This reduces the harvester's revolutions by 16 or 26 %.

Revolutions must be adjusted to progression speed. When the main digging web has the same speed as the tractor, the most gentle handling of the potatoes is achieved. The proportion between the P.T.O. and web speed is:

**Main web speed (km/h) at given**

PTO speed Sprocket size	300 rpm	350 rpm	400 rpm	450 rpm	500 rpm
19t	3.1	3.6	4.1	4.7	5.1
16t	2.6	3.0	3.5	3.9	4.4
14t	2.3	2.7	3.0	3.4	3.8

## 5.2 Row adjustment

The tractor's wheel setting must be adjusted to the row distance.

Adjust lifting unit's position in the rows using the drawbars turnbuckle (Fig. 40) or the hydraulic lane adjustment (fig. 41). The diabolo rollers must run in the middle of the ridgers.

When opening the field use the wheel steering to get the machine's right hand side wheel to run in the furrow. Otherwise the machine must run straight.

## 5.3. Adjusting the lifting unit

The lifting unit is raised and lowered hydraulically (Fig. 42).

Share depth is adjusted using the diabolo rollers (Fig. 43). The lifting unit is attached to the frame which means that it can twist itself and automatically adjust to an uneven surface. Depth must therefore be adjusted on both diabolo rollers. When the soil contains a lot of clod and stones accurate depth adjustments is extremely important.



**In the operating position, the share's lifting**

**cylinders will usually remain down**, for the lifting unit to flow freely on the diabolo rollers. Exception: When using hydraulic floatation unit the cylinder is used to carry part of the weight of the lifting unit.



The large side discs will cut the haulm etc., and should normally be adjusted to penetrate at least 5 cm (2") into the soil. Adjustment is carried out by means of the screw on either side (Fig. 44). Excessive cutting depth can cause the share to be lifted (in particularly in heavy and stony soil) and resulting in potential damage.

The haulm pulling rollers rotate on the belt. If they do not grip the haulm, spring tension must be increased (Fig. 45). Check that the rollers do not touch the side plate or side disks. Note that the rollers must be angled, with the minimum clearance towards the side plate of lower edge.

When haulm blocks to the sides of the lifting unit, the haulm guides are mounted on the outside of the external roller discs (Fig. 46) (extra).

## 5.4. Share angle



Can be adjusted using the adjustable screws on the share holder (Fig. 47). This also adjust share height in relation to the main digging belt. When there is a problem with the haulm attaching itself to the share frame sides, this can either be avoided or reduced by lowering the share (the entire lifting unit is raised onto the diabolo roller). In this way the frame sides will clear haulm left in the furrows.

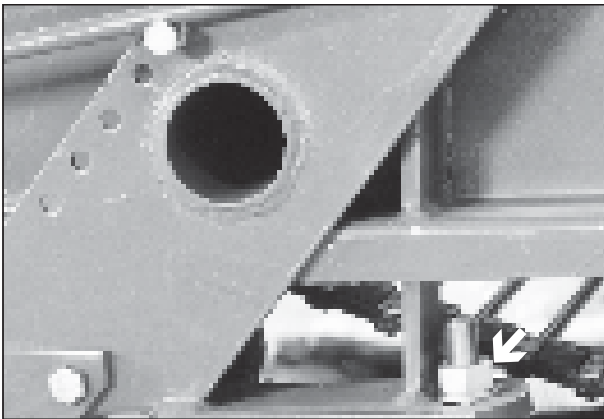

Fig. 47

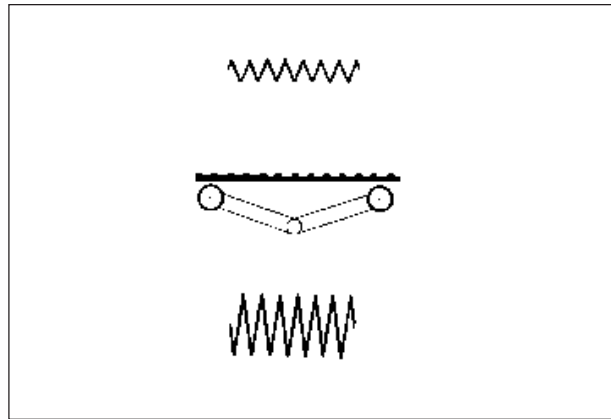

Fig. 48

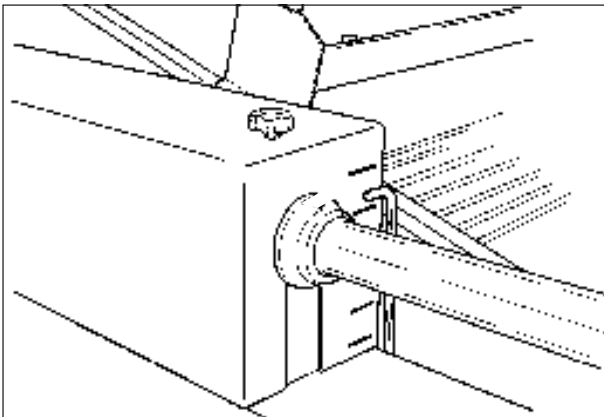

Fig. 49

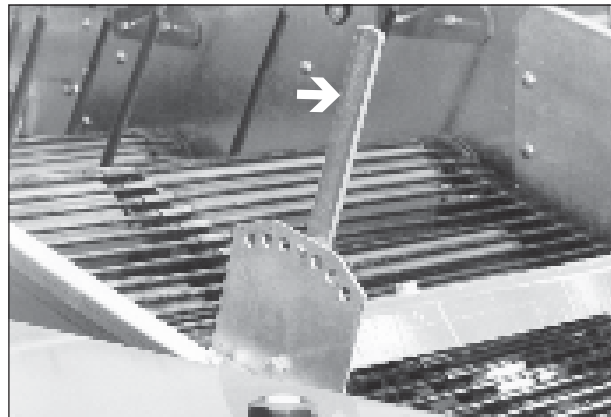

Fig. 50

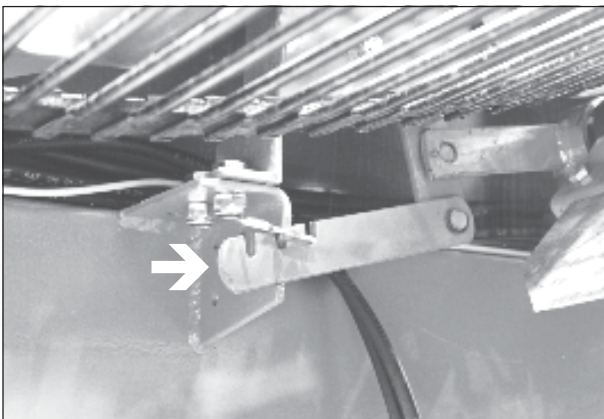

Fig. 51

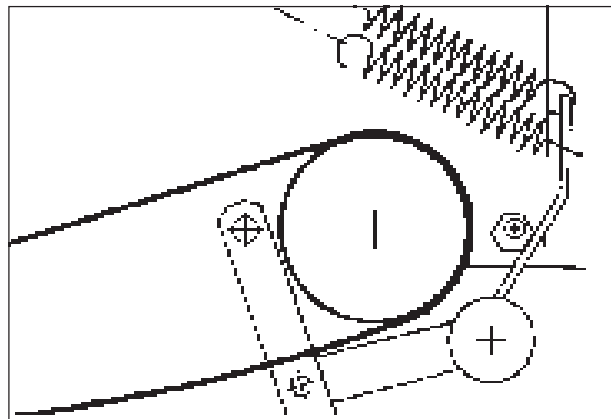

Fig. 52

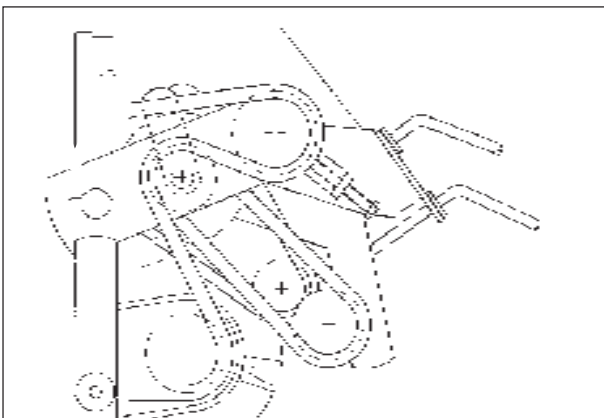

Fig. 53

## 5.5 Belt agitation

The main web agitation is adjusted hydraulically from the machine's control panel (Fig. 48). Agitation intensity can be read on the indicator in the middle of the left hand side of the machine (Fig. 49). Always run with the minimum agitation necessary.

## 5.6 Clod crushing

The two rows of clod crushers on the main web are adjusted using the levers on the right hand side (Fig. 50). Should only be used when necessary.

## 5.7 Haulm removal

### 5.7.1 Haulm rollers



The haulm rollers in the transition between the main and the intermediate web and between the intermediate and hedgehog web can be moved forwards in order to reduce the effectiveness or backwards to increase it. The haulm rollers are moved using the handle at either end (Fig. 51). In the far back position the haulm rollers will be able to grab the potatoes and damage them. The mid position should be used during normal operating conditions.

The clearance between the haulm rollers and the web can be adjusted by turning the eccentric haulm roller pins at either end (Fig. 52). Normal distance is approximately 2-3 mm.

The haulm guides across the haulm rollers adjust the amount of haulm taken on to the rollers. The forward haulm roller should therefore have fewer haulm guides than the one to the rear, for the haulm to be distributed evenly between the two haulm rollers.

### 5.7.2 Haulm elevator

The haulm elevator can be used for separating small stones, clods and remaining haulm and weed. The cleaning efficiency depends on how easy the substance is moved by the elevator belt.

Maximum cleaning is achieved when working speed and/or working angle is set allowing some potatoes to follow all the way to the top of the elevator.



**Observe! In stony conditions this may cause increased damage to the tubers due to stones continually hitting the tubers.**

Set working speed with control valve on the righthand side. The working angle is set from the tractor cab.

Set the spring pressure of the top roller to remove potatoes from the haulm.

## 5.8 Cleaning web



The hedgehog web's cleaning effect is extremely dependent on the position of the spiral rollers and the cleaning roller (Fig. 53).

The distance of the spiral roller to the hedgehog belt is adjusted using the adjustment screw at either sides. The most favourable position depends on the size of the potatoes (small potatoes - small distance, large potatoes - big distance). The spiral roller should not be pushing up against the hedgehog, this gives a poor cleaning effect and considerable wear on the roller and belt.

If the cleaning roller behind the spiral roller is adjusted out, this will result in the potatoes using more time on the spiral roller. This achieves improved cleaning. The cleaning roller should not be adjusted so far down that it touches the hedgehog belt.

The rollers must be adjusted in or out using the adjustment screws on either side of the machine

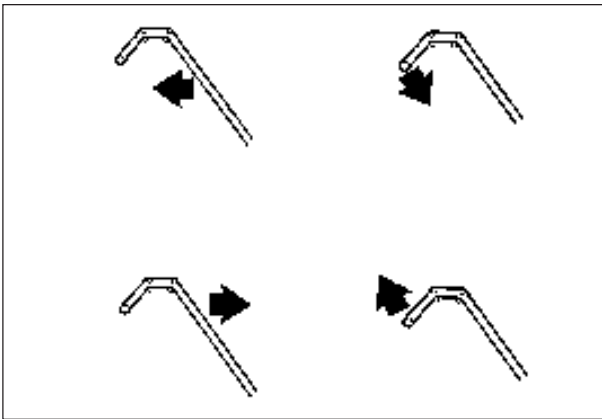

Fig. 54

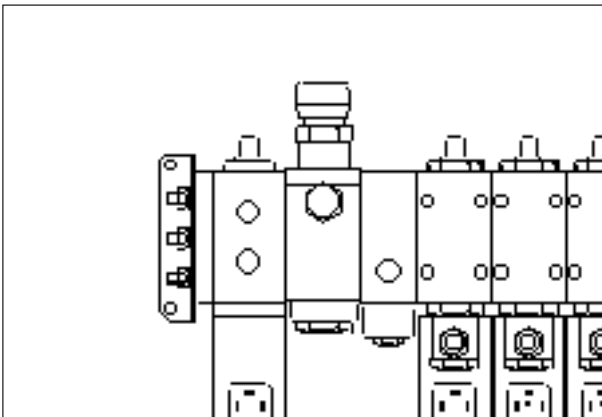

Fig. 55

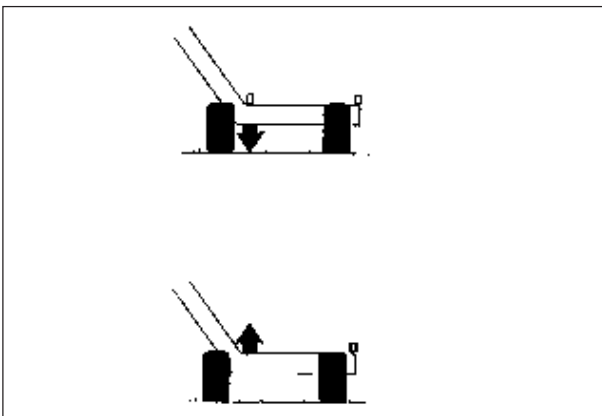

Fig. 56

(Fig. 53).

The rollers can also be moved up or down in order to change the aggressiveness of the cleaning belt. The attachment plates are loosened in the frame and turned. Remember to adjust the chain tensioning.

In stonefree soil conditions with little haulm and large amounts of potatoes, the rollers should be lowered.



Be careful to ensure that the deflectors lay parallel with the hedgehog belt. This prevents blocking due to haulm which can block under the guards.

Observe! The settings of the cleaning web system depends very much on the machine's speed. Therefore, keep steady engine speed on tractor!

## 5.9 Discharge elevator

The elevator is hydraulically operated from the tractor's cab (Fig. 54).



The elevator must be lowered prior to starting.

The range is dependent on loading height, and can be adjusted mainly using the elevator's bottom cylinders. Loading height must be adjusted using the outer part of the elevator.

Elevator speed can be adjusted using the volume adjustment valve at the back of the hydraulic services (fig. 55) (put your hand into the hole at the back of the central guard and turn the wheel). When using the combined windrowing system the speed is adjusted from the control panel in the tractor cab. Maintain the minimum speed for the elevator's pockets to fill properly. This provides gentle transportation.

If the elevator has a hopper chute one must be aware of the danger of haulm etc. accumulating and blocking the opening.

If the harvester has a picking table canopy, the front part of this must be collapsed before the elevator is put in a transportation position.

## 5.10 Picking table

The speed of the picking table can be adjusted on the flow control valve at righthand side of the picking table.

The operator platform height can be adjusted in steps.

## 5.11 Axial cleaning rollers

### 5.11.1 Roller speed

The speed is controlled by operating the flow control valve at the rear side of the picking table. A high speed is recommended. Speed and angle should be set according to the working conditions.

Max speed is approx. 35% above the PTO speed.

### 5.11.2 The angle of the roller unit

Adjust the angle by operating the handle on the rear end of the picking table. High capacity is achieved by a fairly flat unit, while a steep unit offers a more gentle handling of the crop. Speed and angle should be set according to the working conditions.

### 5.11.3 Hydraulic working pressure

When running empty the hydraulic pressure should be approx. 40 bar. Working hard the pressure may reach approx. 80 bar. The auto reverseing system is activated at approx. 110 bar.

### 5.11.4 Auto reversing system

The auto reversing system is preset at the manufacturer and should normally not be reset by the operator. Control the function by pressing the button on the electronic control box. The rollers will reverse for a very short period (0.1 sec).

### 5.11.5 Roller scrapers

The scrapers of the smooth rollers will improve the cleaning efficiency in sticky conditions.

The building up of soil on the rollers even depends on the roller speed. It is recommended to run without scrapers due to the risk of severe roller wear. Try to speed up the rollers a bit to reduce the building up of soil.

## 5.12 Alarm

The alarm is operated by pulling the cord alongside the picking table. Agree an alarm code with the tractor driver for the various operations; for example Start, Stop, Reduce speed, Increase speed.

## 5.13 Levelling

The machine can be lowered or raised hydraulically on the right hand side (Fig. 56). This function is used on slopes in order to get an even distribution of the potatoes across the entire width of the machine. The transportation support must be folded in order to lower the machine.

## 5.14 Adjusting machine's height on wheels

The wheel axle has three positions. The upper position is used when fitting standard wheels 500/50-17". If bigger wheels are used, the wheel axle must be moved down if necessary (both the frame attachments, the cylinder's attachments to the frame and the transportation support attachment to the wheel axle.)

If the wheel dimensions so permit, the machine can be lowered to reduce the belt angles (recommended for onions in order to get the windrow to slide more easily onto the belt), or increase the angle in order to increase the soil separation.

## 5.15 Picking table canopy

The front part of the canopy must be lowered before the elevator is put in a transportation position.

The rear canopy side can be rolled up to improve ventilation in hot weather. In strong wind conditions the sides must be fastened correctly.

# 6 MAINTENANCE

## 6.1. Wheel pressure

Tyre dimension	Normal pressure	Maximum pressure
500/50-17", 8 ply	1.2 kp/cm <sup>2</sup> (17 psi)	1.6 kp/cm <sup>2</sup> (22 psi)
400/55-22.5", 8 ply	1.6 kp/cm <sup>2</sup> (21 psi)	2.0 kp/cm <sup>2</sup> (28 psi)
500/45-22.5", 8 ply	1.2 kp/cm <sup>2</sup> (17 psi)	1.6 kp/cm <sup>2</sup> (22 psi)
500/60-22.5", 8 ply	1.2 kp/cm <sup>2</sup> (17 psi)	1.6 kp/cm <sup>2</sup> (22 psi)
12.4/11-24", 6 ply	2.2 kp/cm <sup>2</sup> (31 psi)	2.2 kp/cm <sup>2</sup> (31 psi)

## 6.2 Belt tensioning

### Main digging web

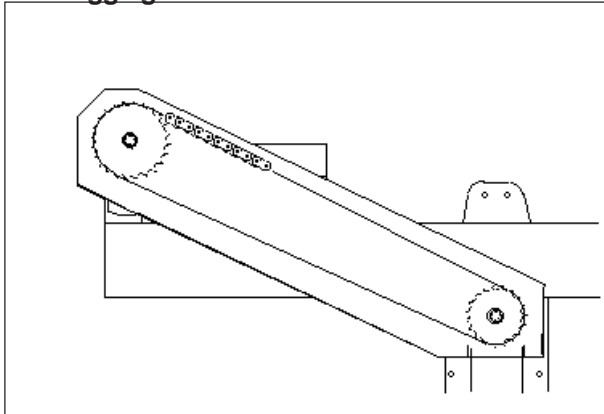

Fig. 57

No tensioning

### Intermediate web

Automatic spring tensioning. Springs must be tensioned as belt is slipping.

### Hedgehog web

Automatic spring tensioning. Springs must be tensioned as belt is slipping.

### Third web

Forward screw tensioning

### Haulm elevator

Automatic spring tensioning. Springs must be tensioned as belt is slipping.

### Picking web

Rear screw tensioning.

### Return web

Rear screw tensioning.

### Elevator

Lower bottom screw tensioning (Fig. ??).



**Note!** Make sure that the belts are adjusted equally on both sides, for these to run straight.



Fig. 58

## 6.3 Drive chain tensioning

### Main drive chain

Move drive shaft to the left for tensioning to change. Loosen screws securing the bearings housing. Use screw in left-hand side (Fig. 57).

### Drive chain first haulm roller

Spring tensioning

### Drive chain intermediate web

Spring tensioning.

### Drive chain second haulm roller

Spring tensioning.

### Drive chain hedgehog web

Spring tensioning.

### Drive chains cleaning belt rollers

Tensioning levers (Fig. 58)

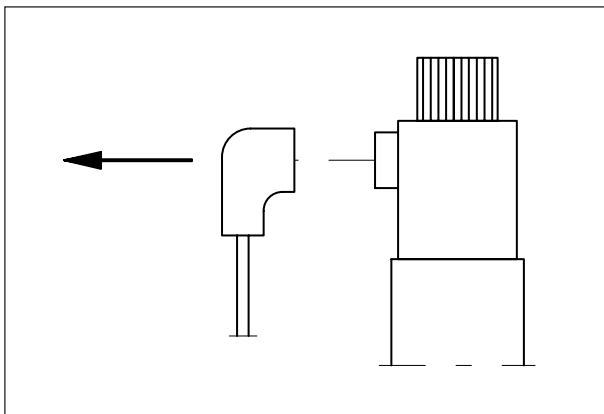

Fig. 59

## 6.4. Lubrication

See Fig. 64.

Follow the manufacturer's instructions for lubricating P.T.O. shaft/universal joint/safety clutches/wheel bearings.

## 6.5. Oil filters



The harvester's oil filter should be changed annually. Do not forget the tank filter on machine with integrated pump (axial rollers). State model number (manufacturer) when ordering.

### Filter type Ordering no.

#### Pressure filter element:

Argo .....	300871
MP .....	300873
Parker .....	306685

#### Return filter (tank):

FBO CR180/1 .....	306577
-------------------	--------

## 6.6. Oil change

### For machine with integrated oil pump only:

#### Hydraulic oil

Change oil after 200 hours and thereafter every 500 hours using oil type HD46. Quantity 2200 approx. 45 litres.

#### Pump gear oil

Change oil every 200 hours. Oil type gear oil SAE80/90. Quantity 0.45 litres.

#### Roller gear oil

Change oil after 100 hours and thereafter every year. Use oil type ISO VG680/DIN CLP-3. Quantity 3.5 litres. Drainage plug underneath the gear box. Fill through plugged opening on righthand side.

## 6.7. Hydraulic valve bank



When working in dusty conditions, the top of the valve bank should be covered by some kind of filter material (rubber sponge) in order to prevent dust from intruding the valves through the caps on top of the spool guides. Clean the filter every season.

## 6.8. Axial rollers

### 6.8.1 Rollers

The auger roller should be fitted at the lefthand side of the cooperating smooth roller. The rollers are connected to the drive shafts using centrally positioned splines. When worn (appears normally on the rear end of the rollers) they can be reversed.

### 6.8.2 Resetting of the auto reversing system

- a. Stop machine and block the rollers with the plug on the righthand end of the gear box. Turn the gear wheel with a screw driver, to let the plug get between two teeth.
- b. Disconnect the power cable on magnetic valve (fig. 59).
- c. Loosen locknut for the relief valve screw (fig. 60), and unscrew *onreturn*.
- d. Start the tractor and let the harvester run at idle speed.
- e. Adjust relief valve screw (fig. 60) until pressure gauge shows 110 bar.
- f. If red lights are on, screw pressure relief valve (fig. 61) in until lights turn off. Then screw pressure relief valve out again until the lights flash. Now the pressure relief valve is set to reverse rollers at 110 bar.
- g. Now adjust relief valve screw further in, until pressure gauge shows 130 bar. Lock relief valve screw with lock nut. This operation is required to set the relief valve at a higher pressure than the pressure controller (130bar against 110bar).
- h. Stop harvester. Set lock plug in end of gear box in normal position.
- i. The electronic box has two time-delay relays. The first relay controls the reversing time when the rollers are blocked. The setting should be 0.1 sec. (0.3 on scale). The second relay should be adjusted on longer time to prevent further short pressure fluctuations produce another reverse by activating the first relay. This will allow the rollers to stabilize and run normally. The setting is 0.5 sec (1.5 on scale).

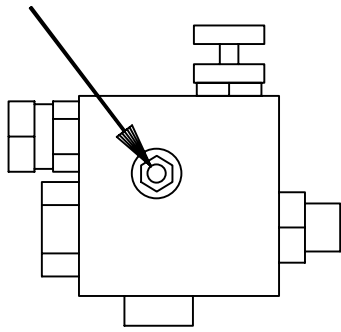

Fig. 60

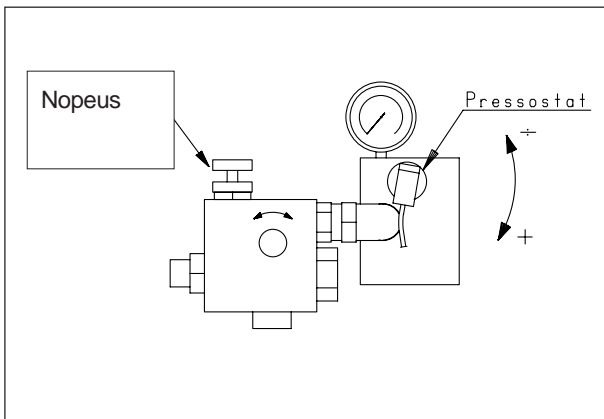

Fig. 61

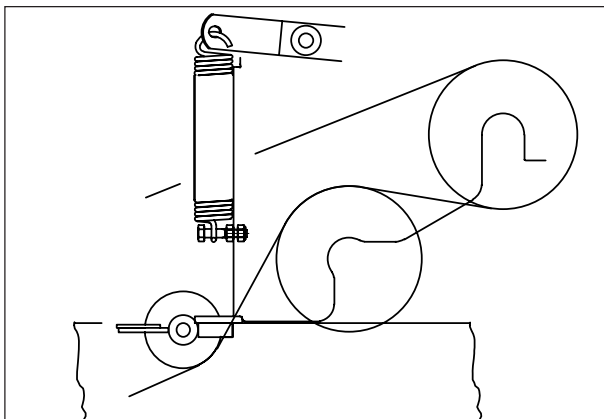

Fig. 62

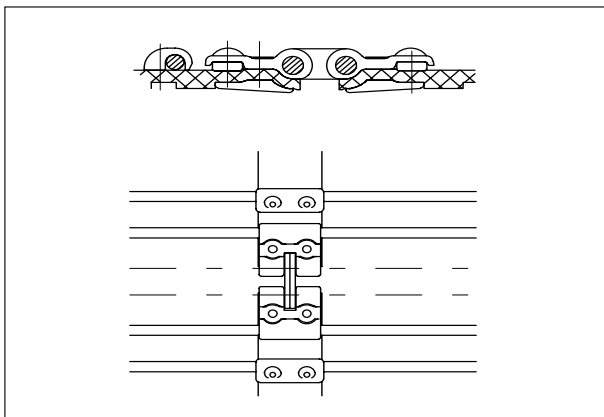

Fig. 63

## 6.9. Cleaning



By removing soil from side guards etc. regularly this will prevent unnecessary blocking of and damage to potatoes. Take care to remove soil and haulm which build up inside the belt.

When cleaning the machine after each season care must be taken when using the high pressure hose as this can damage the bearings.

Smooth surfaces should be protected against rust. This is particularly important for shares and large side discs. Remove any building up of soil and trash regularly in order to avoid severe wear of the rollers. By removing the nylock nut attaching the galvanized bar in the centre of the rear end of the picking table, the rear guard can be tilted backwards.

Stop the tractor and remove the ignition key while this type of maintenance is performed.

## 6.10. Main web drive



When the main web start slipping any possible reason for this should be eliminated, if possible. The reason for web slippage is an obvious overload on web and drive system. This may come from soil being built up on the share arms, roll of soil and trash being built up in the web at the share, scrapers catching the web (especially the joiners), much soil on the web (heavy soil or web with small gaps) or greasy soil causing reduced friction on drive rollers. If reason(s) for slippage is reduced to a minimum and web slippage still occurs, there are three possibilities of improvement by modification of drive system:

- a. Fit optional web tension rollers at the lower drive roller
- b. Fit special rubber drive discs with teeth pitch suiting the web pitch.
- c. Fit positive web drive using steel sprockets on lower drive roller (pitch to suit the web pitch)

## 6.10.1 Web tension rollers at the lower drive roller

(Ordering no. 82219)

Obtain better contact between web and lower drive roller by increase of web tension. To be fitted at the lower drive roller's ends as shown on fig. 62. No change is required when web pitch is altered.

## 6.10.2 Special rubber drive discs with teeth



Fit on upper drive roller only. Replaces the

original universal rubber drive disc. Change of rubber disc pitch is recommended when web pitch is changed. Thus maximum friction is obtained.

Available special rubber drive discs:

Web pitch	No. of teeth	Ordering no.
36mm	26	4 x 303510
40mm	30	4 x 303520
45mm	35	4 x 303530

## 6.10.3 Positive web drive using steel sprockets

### a. Drive modification

Main web drive has normally universal friction drive fitted (rubber drive discs at all rubber belts on upper and lower drive roller). In extremely heavy conditions the steel sprockets fitted on the drive roller stop web slippage.

When the *web type 4* (cast centre clips and double ljoining links, see fig. 63) is fitted, the web steel sprockets should be fitted on the *lower* drive roller. Remove the outer rubber drive discs and the retaining plates. Use the proper sprocket kit according to the web pitch:

Web pitch	Rod gap	No. of teeth	Sprocket kit no.
28mm	17mm	24	82214
36mm	25mm	18	82215
40mm	29mm	16	82216
45mm	34mm	14	82217
50mm	39mm	13	82218



The *lower* drive roller should have the 36 teeth

ratchet chain sprocket with overrun hub fitted. This replaces the fixed 31 teeth on the lefthand end of the roller. Extend the drive chain. **Observe! When fitting friction drive once more the fixed 31 teeth sprocket should be refitted.**

Ratchet sprocket kit with scrapers ordering no. 82213

On early models with 3 bolt holes for the rubber discs on lower roller (easy to recognize from the retaining disc outside the rubber discs) the drive system described above can *not* be used. In such case a different web sprockets have to be fitted on *upper* drive roller. Contact your Kverneland representative for further information. When fitting web sprockets on upper drive roller the chain sprocket on lower drive roller should not be exchanged. When using web sprockets the scraper at the ends of the roller should be modified. For lower drive roller the scrapers included with ratchet sprocket kit 82213 should be fitted.

### b. Web requirement when using positive web drive

When the web sprockets are fitted on the lower drive roller, the Kverneland web type 4 (cast centre clips and double joining links, see fig. 63) should be used. This web type offers uniform web pitch even at the joiners.

Other web types with single joiners offers deviant rod gap at the joiner when web runs over the lower drive roller. Such web types need to have joiners with following pitch:

Web pitch	Joiner pitch
28mm	28mm
36mm	36mm
40mm	36mm
45mm	40mm or 42mm
50mm	45mm

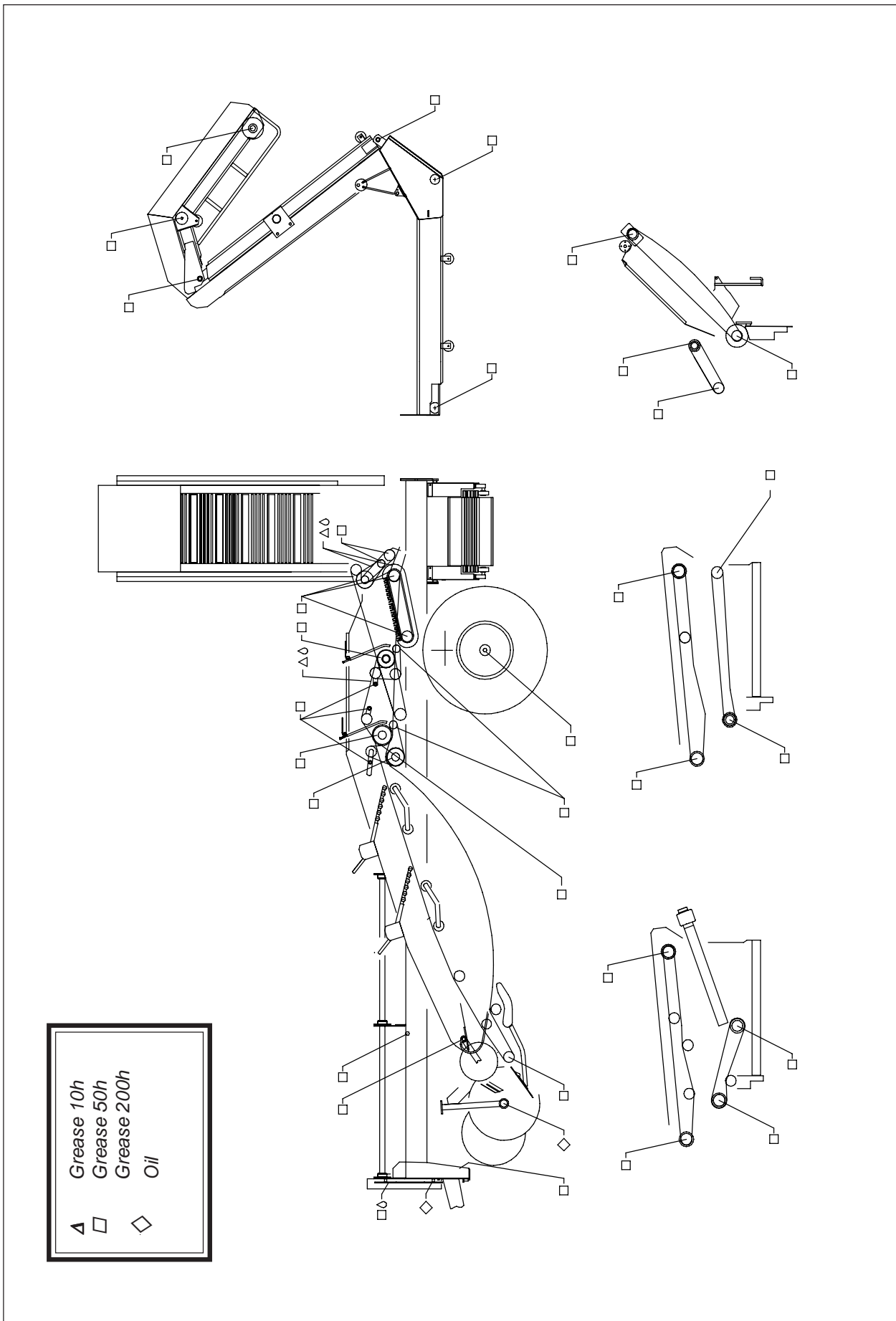

Fig. 64a

<i>D</i>	□	◇
Grease 10h		
Grease 50h		
Grease 200h		
Oil		

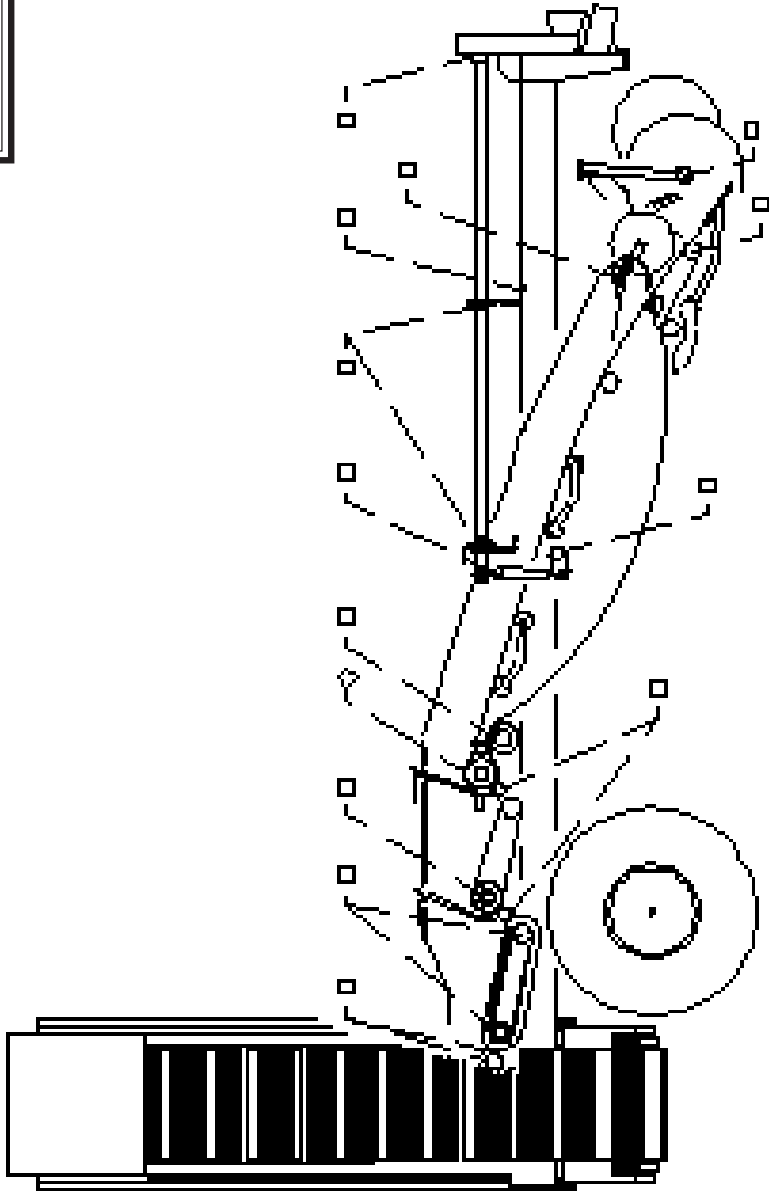

Fig. 64b

## 7. TROUBLE SHOOTING

### Symptom

### Action

#### Hydraulic, electrical and mechanical faults:

Hydraulic services failure

Check that solenoids are activated  
Change main hoses round or turn oil flow  
Check that end plate screw is in the correct position  
(see paragraph 3.4)

The levelling cylinder moves up as  
the oil pressure is on

No return to tank, check coupling

Hydraulic services work only when valves  
are being manually operated

Check if the solenoid voltage minimum 10.8 V.  
Connect control panel with a larger wire  
A wire has been cut, or control panel switch fails  
Fuse failure in the control panel

Remote control only possible for one function  
at the time

Large drop in voltage connect control panel with a  
larger wire cross section

Tractor's safety valve opens

Unscrew centre screw in the centres front end plate

Tractor's steering is jerky (John Deere)

Screw in centre screw in spool valve's front end plate

Harvester alarm failure

Change round the wires in the control panel socket  
Wire breakages

Safety couplings trip during operation

Check that conveyors and rollers are not blocked by  
stones etc.

Tighten couplings

The hydraulic lane adjustment works slowly

Large drawbar pivot bolt friction. Grease bolt.

#### Haulm blocking and haulm removal:

Haulm attaches itself to share frame

Fit haulm guides. Increase share angle and raise lifting  
unit using diablo roller

Sharpen the discs

Haulm gathers by the haulm guides

Remove a haulm guide (distribute the rest evenly  
across machine width)

#### Loss of potatoes:

Potatoes left in the ground

Adjust share depth using diablo roller

Lower lifting cylinder for the shares as far down as  
possible

Loss of potatoes by roller discs

The distance between the roller discs and the belt or  
between the roller discs and share is too great  
Roll-back plates between the centre roller discs do not  
function

## Symptom

## Action

Potatoes drop through conveyor

Use web with smaller spacings or check web for damages

Loss of potatoes by haulm roller

Tension haulm roller springs  
Move haulm roller forwards  
Remove haulm guides from forward haulm roller in order to get more of the haulm to the second haulm roller. Increase harvester revolutions

Use haulm pulverizer  
Reduce forward speed

Loss of potatoes on hedgehog belt

Lower spiral roller  
Move spiral roller closer to the hedgehog belt  
Lower deflectors

### Damage to crop:

Potatoes damaged in row

Tyre crushing damages.  
Use narrower tyres, adjust correct wheel setting on the tractor

Damages caused by harvester

Digging web agitation too strong  
Web gap too wide  
Web speed too high  
Forward speed too low  
Share adjustment too shallow  
Roller discs too far in  
Poor climate (cold, wet)  
Stony soil

Damages caused by loading

Elevator drop too great. Lower elevator, use the chute.  
Careless handling of the potatoes



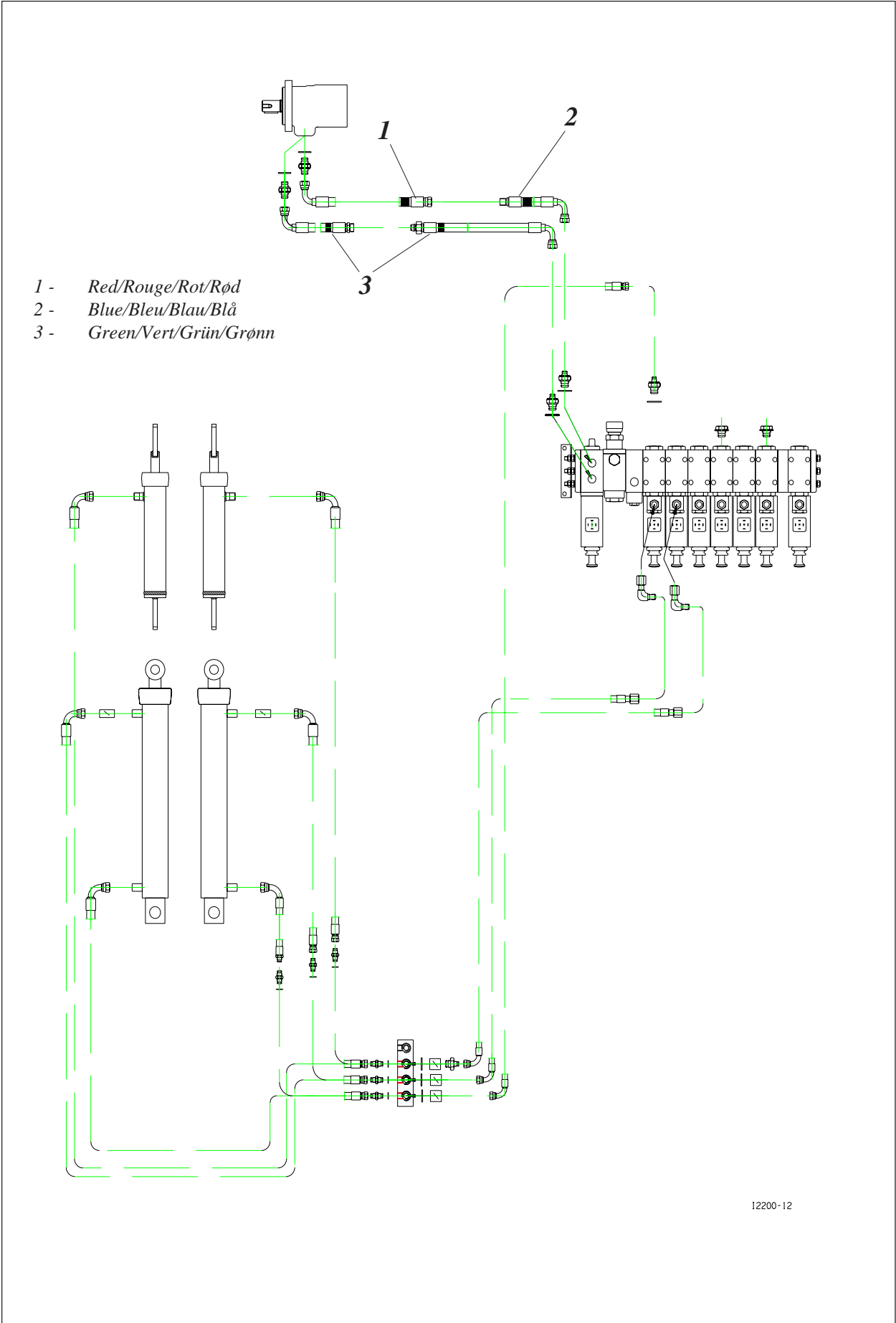
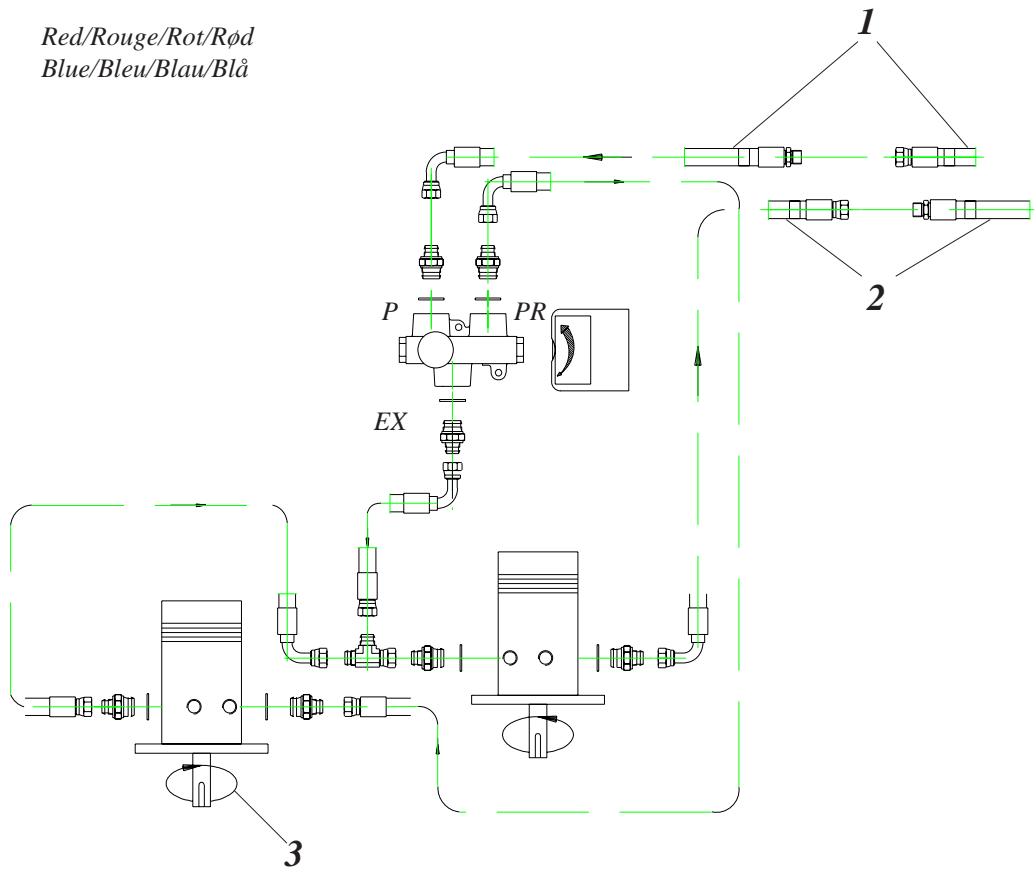

Fig. I

- 1 - Red/Rouge/Rot/Rød
- 2 - Blue/Bleu/Blau/Blå



- 3 - Picking web  
Table de triage  
Verleseband  
Sorterbelte

Fig. II

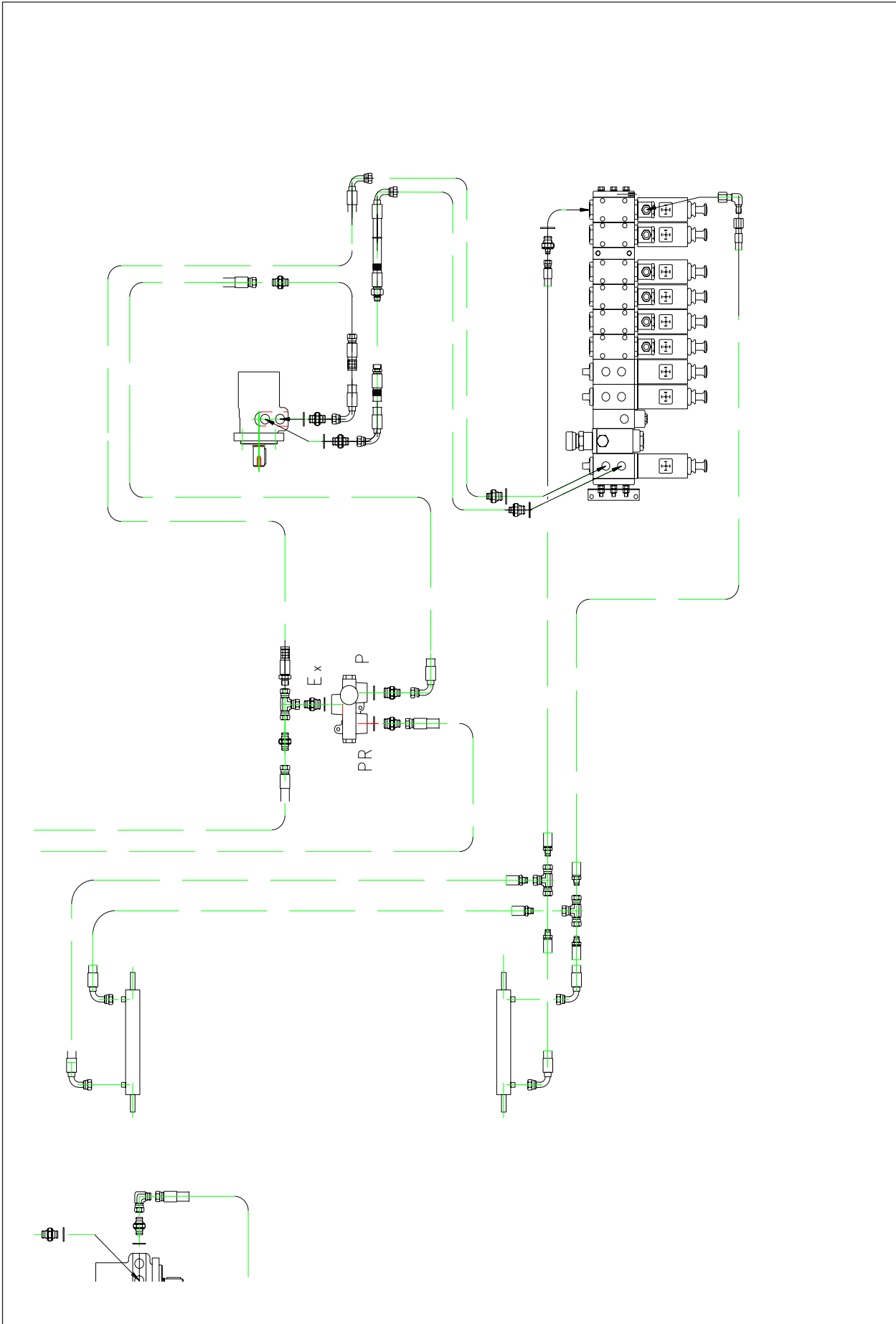

Fig. III

For 2220 & 2222:

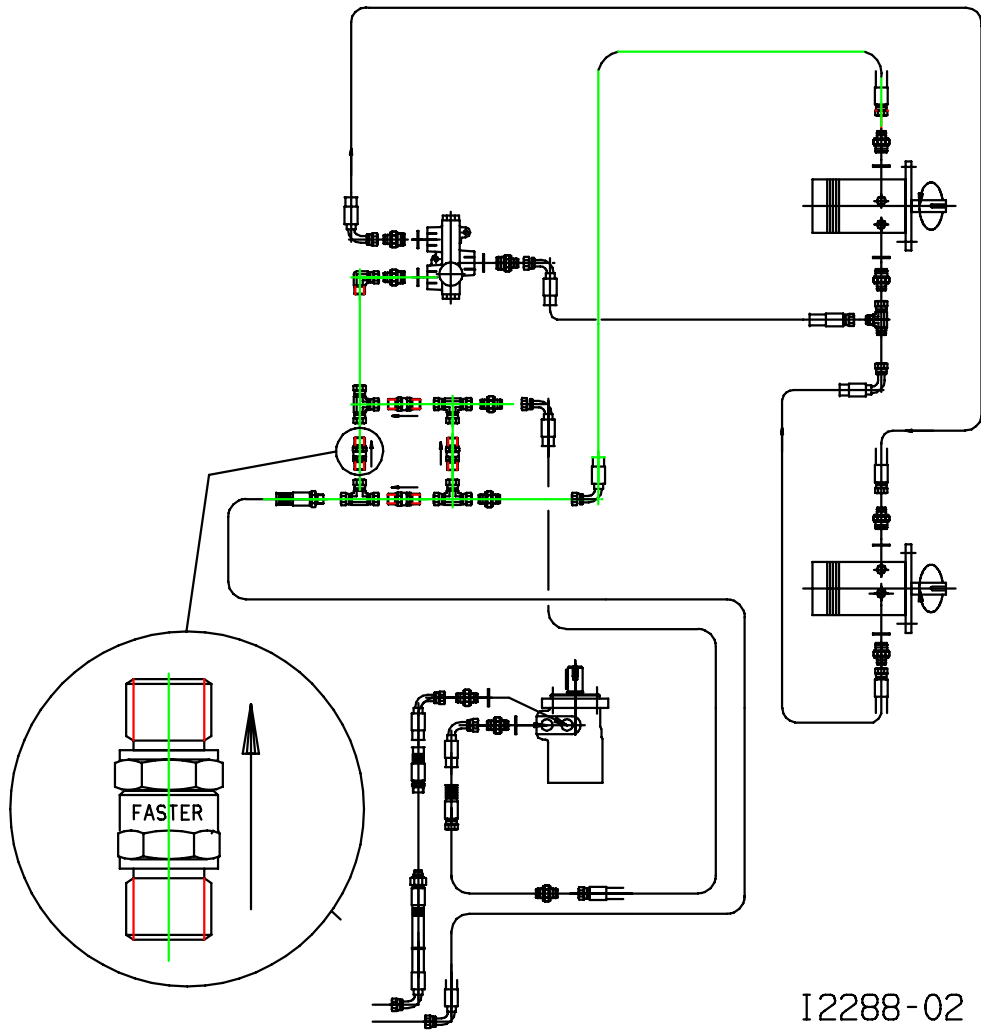

Fig. IVa

*For 2212:*

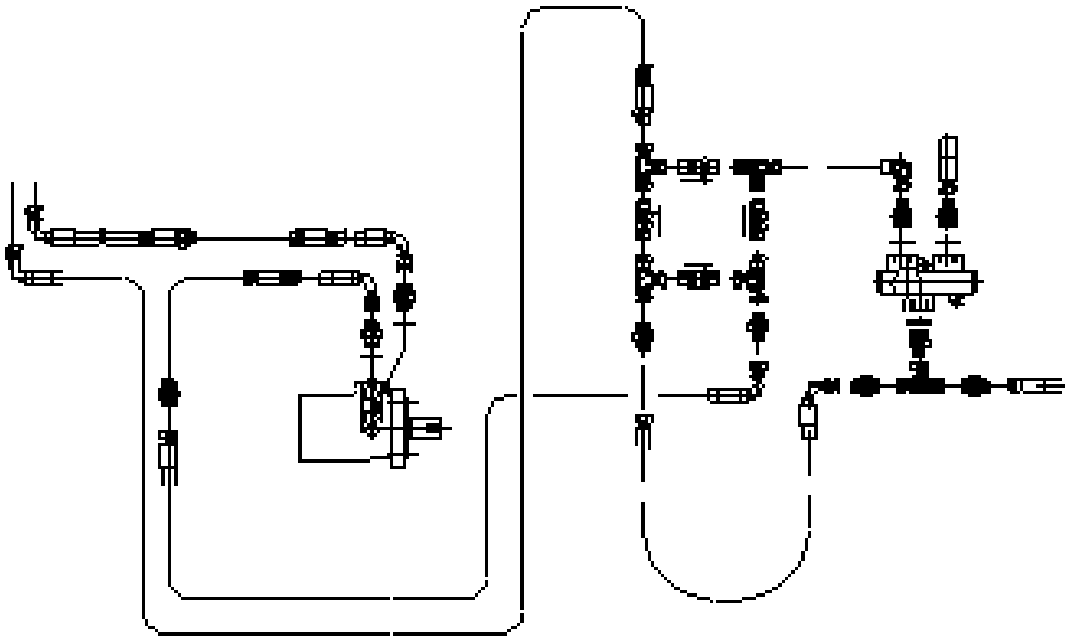

Fig. IVb

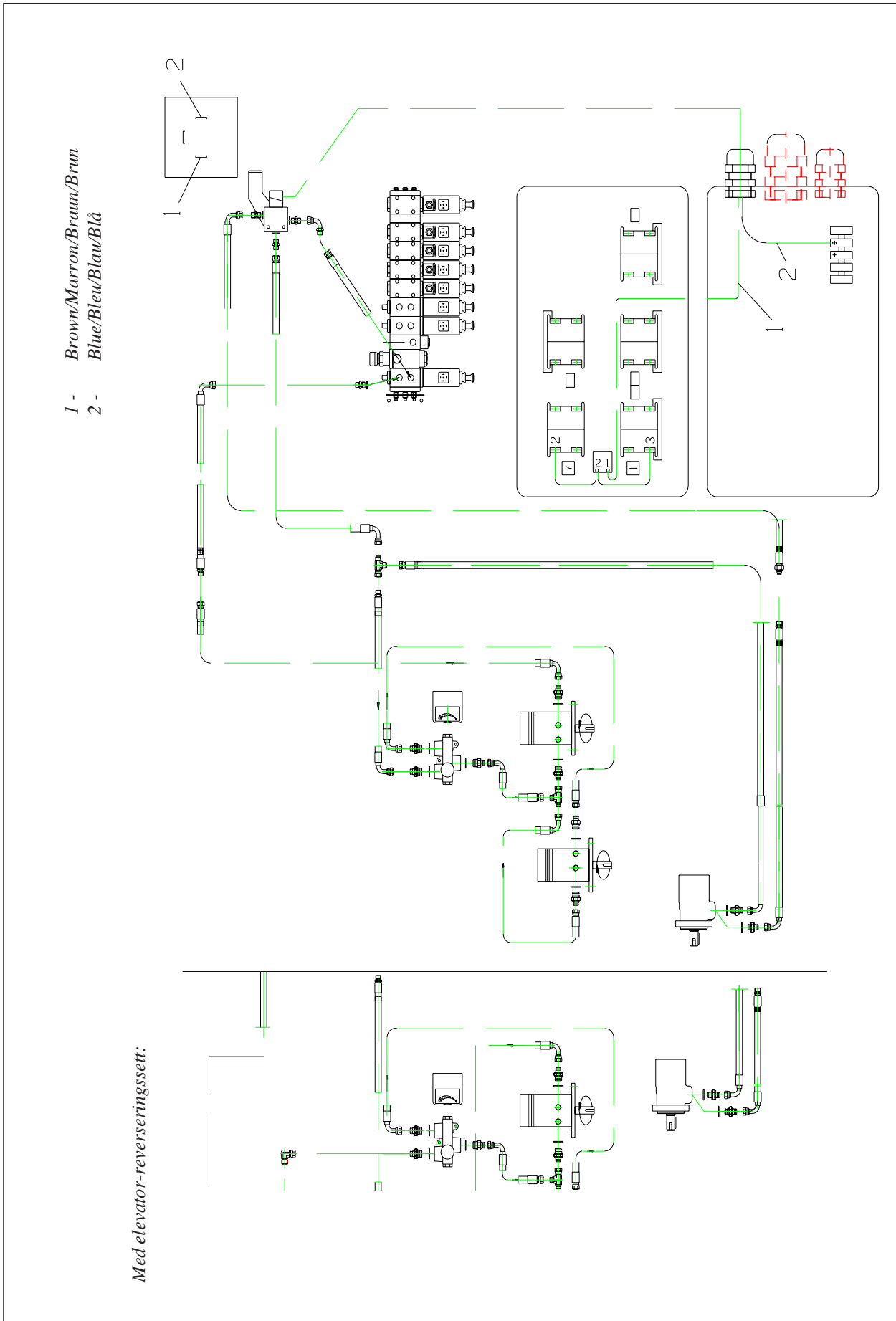

Fig. V

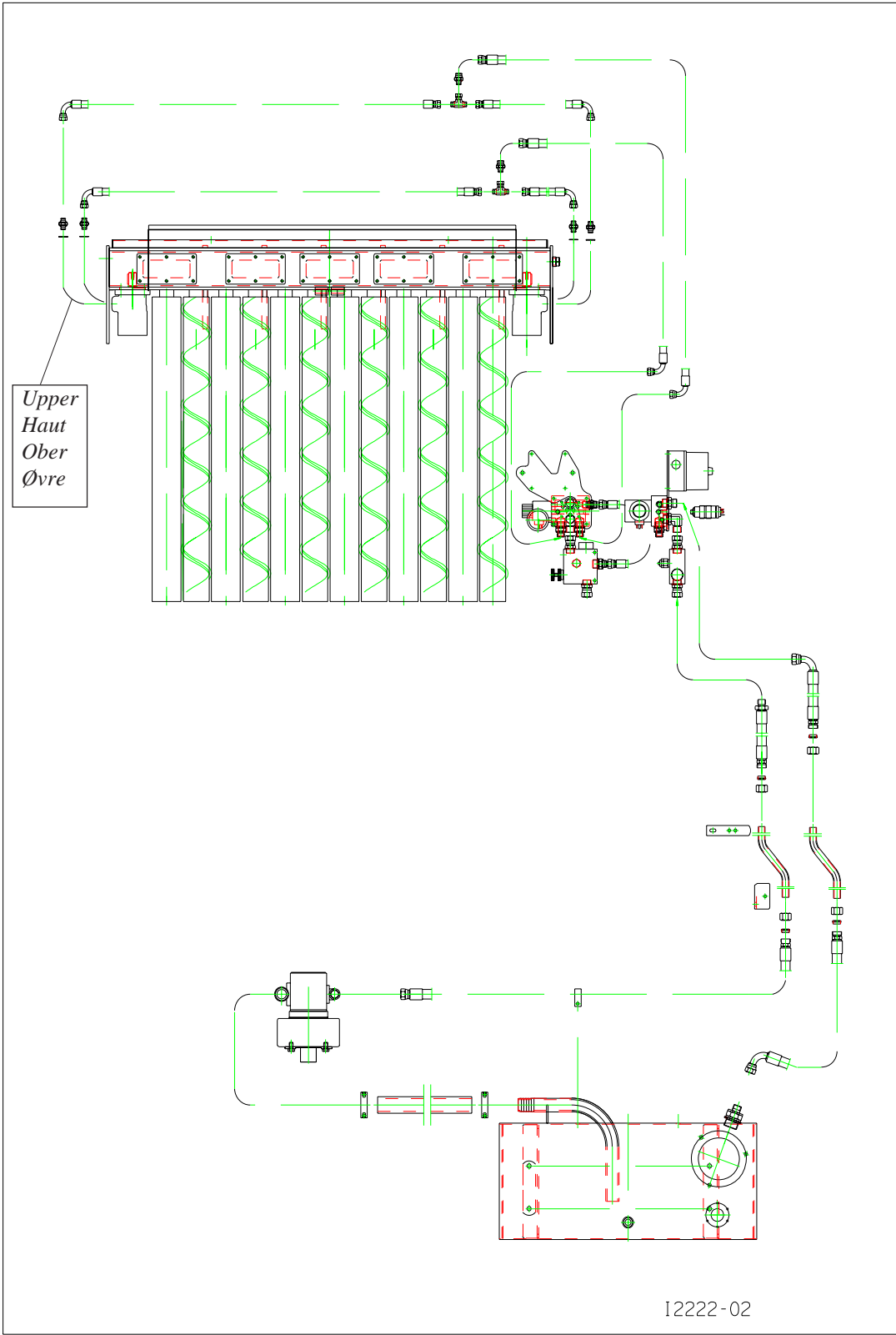

Fig. VI